

**R44-series Horizontal Stabilizer Retrofit Kit Instructions**

To determine eligibility for installation, refer to R44 Service Letter SL-89A. Kit replaces C044-1 horizontal stabilizer with F044-1 vertical stabilizers mount assembly, and installs F050-2 horizontal (symmetrical) stabilizer assembly. Kit is not approved for installation on Raven I helicopters fitted with C169-1 exhaust muffler assembly, which has a shroud diameter of 6.0 inches. C169-35 exhaust muffler assembly, or C169-36 muffler sub-assembly may be installed to meet kit installation requirements. Replacement of B264-XX connector of tailcone aft wiring may be required; refer to KI-276.

**NOTE**

Visit <https://robinsonheli.com> to verify kit instructions are current revision. Review instructions before installation; contact RHC Technical Support with questions. Verify kit contents match list; contact RHC Customer Service if parts are missing or damaged.

ITEM	PART NUMBER	KIT CONTENTS	QTY
1	KI-285-2Instr.	Kit Instructions . . . . .	1
2	A654-3	Decal – “DANGER” . . . . .	2
3	B330-19	Palnut . . . . .	2
4	B900-15	Component Modifications Plate . . . . .	1
5	D210-3	Nut . . . . .	4
6	D210-6	Nut . . . . .	2
7	F044-1.CS*	Vertical Stabilizers Mount Assembly . . . . .	1
8	F050-2.CS*	Horizontal Stabilizer Assembly . . . . .	1
9	F955-2**	Doubler (This part will be provided unless alternate part [below] is selected.) .	2
	F955-2.CS*	Doubler . . . . .	0
10	F955-4**	Stiffener Assembly . . . . .	4
11	F955-6**	Bracket (Field; This part will be provided unless alternate part [below] is selected.) . . . . .	1
	F955-6.CS*	Bracket (Field) . . . . .	0
12	MT830	Locator Tool – Horizontal Stabilizer (one-time use) . . . . . Includes: [1] MT830-1 Bracket [1] MT830-2 Cover [2] MT830-3 Plate [1] MT830-4 Template	1
13	MS3367-4-9+	Ty-rap (Note: “+” in part number indicates 20-qty pack) . . . . .	1
14	MS3367-5-9+	Ty-rap (Note: “+” in part number indicates 20-qty pack) . . . . .	1
15	NAS1149F0332P+	Washer (Note: “+” in part number indicates 20-qty pack) . . . . .	1
16	NAS1149F0432P+	Washer (Note: “+” in part number indicates 20-qty pack) . . . . .	1
17	NAS1149F0632P+	Washer (Note: “+” in part number indicates 20-qty pack) . . . . .	1
18	NAS1149F0663P+	Washer (Note: “+” in part number indicates 10-qty pack) . . . . .	1
19	NAS6603-2	Bolt . . . . .	4
20	NAS6604-3	Bolt . . . . .	4

ITEM	PART NUMBER	KIT CONTENTS (continued)	QTY
21	NAS6606-47	Bolt . . . . .	2
22	NAS9301B-5-02	Blind Rivet (includes 7 extra) . . . . .	35
23	NAS9301B-5-03	Blind Rivet (includes 4 extra) . . . . .	10
24	NAS9301B-5-04	Blind Rivet (includes 2 extra) . . . . .	10

\* “.CS” suffix indicates part has paint finish options; contact Customer Support.

\*\* Finish is primer only.

**Consumables**

Refer to R44 Maintenance Manual (MM) § 23-70 for approved materials list.

- B270-1 Sealant

**Special Tools**

- Precision hand drill (less than 0.001 inch runout measured 1 inch from chuck)
- Drill sizes #11, #21, #30, 1/4-inch, and F, with corresponding drill stops
- Deburring tool
- Clecos – sizes #11, #21, and #30
- Step drill
- 12-inch (minimum) straight edge
- Precision bubble or digital protractor, having 0.1 degree resolution
- Rivet puller, suitable for structural #5 blind rivets
- #30 hole finder

**Kit Instructions**

1. Ensure ignition switch is OFF; remove key. Turn BATTERY switch OFF.

**NOTE**

For the purpose of this kit installation, it is not necessary to remove D081-1 spacer when removing tail rotor guard (refer to MM Figure 4-5).

2. Remove C044-1 horizontal stabilizer assembly, including D301 ballast weights (if installed) per MM § 4.640. Remove & retain tail light per MM § 26-12. Discard palnuts & nuts and retain remaining hardware. Remove DANGER decal from both sides of tailcone per MM § 21-10. Remove inspection plugs from tailcone.
3. Visually inspect four rubber mounts on main rotor gearbox and verify no contamination or damage; replace as required. Level helicopter per MM § 18.10.

**CAUTION**

Prior to drilling, inspect opposite side for obstruction(s). As required, relocate and/or remove obstruction(s).

4. Refer to Figure 1. Locate four specified rivets (4th, 5th, 8th, and 9th), counting from first rivet as shown. Drill out specified rivets using #30 drill fitted with drill stop.

**Kit Instructions (continued)**

5. Refer to Figures 2 & 3. Place MT830-1 bracket on tailcone, with apex of bottom cut-out pointing forward. Secure bracket to tailcone with clecos at drilled-out rivet holes. Attach MT830-2 cover, wider-end forward, to bracket using clecos.
6. Refer to Figure 4. Place protractor laterally across forward posts of MT830-1 bracket as shown and verify locator tool is level (use straight edge atop posts if protractor cannot contact both posts). As required, rotate locator tool on tailcone by lightly tapping with a rubber or plastic mallet, until protractor indicates level/zero. Repeat procedure with protractor placed laterally across aft posts.

**NOTE**

Once protractor/level indicates zero with first reading, subsequent readings are allowed a tolerance of  $\pm 0.5$  degree.

7. Refer to Figures 3 & 5. Using LH aft hole in bracket as template and a drill with drill stop, drill (1) 0.190–0.196 inch diameter hole and install cleco thru C023-11 skin. Verify locator tool remains level. At RH aft hole in bracket, drill (1) 0.190–0.196 inch diameter hole thru skin and install cleco.
8. Place protractor across forward posts of bracket and verify locator tool is level within 0.5 degree; adjust as required. At LH forward hole in bracket, drill (1) 0.190–0.196 inch diameter hole thru skin and install cleco. Verify locator tool remains level. At RH forward hole in bracket, drill (1) 0.190–0.196 inch diameter hole thru skin and install cleco. Remove protractor and straight edge (if used). At LH & RH middle holes in bracket, drill (2) 0.190–0.196 inch diameter holes thru skin. Remove clecos and locator tool.
9. Refer to Figure 5. Using 1/4-inch drill fitted with drill stop, enlarge (2) forward & (2) aft pilot holes, to 0.250–0.255 inch. Using a step drill enlarge (2) middle pilot holes to 0.75 inch. Deburr all newly drilled holes.
10. Refer to Figure 6. Locate (1) F955-2 doubler to tailcone using (2) NAS6604-3 bolts and secure with tape as required. Mark doubler to indicate top & bottom, and left or right side of tailcone. Using doubler as template and a #21 drill fitted with drill stop, begin at center of doubler working outward and progressively match drill 0.158-0.164 inch diameter hole & install clecos thru C023-11 skin (18) places. Remove securing hardware & doubler. Repeat procedure on opposite side of tailcone using remaining doubler.
11. With both doublers removed and using letter “F” twist drill fitted with drill stop, enlarge (2) forward & (2) aft 0.250 inch diameter bolt holes in C023-11 skin to 0.256–0.263 inch final diameter. Deburr all newly drilled holes and clean up debris (strobe light may be removed to facilitate access to tailcone interior).

**NOTE**

At installer’s discretion, solvent-clean deburred edge and apply Bonderite M-CR 1132, or Bonderite M-CR 1201 Aero in accordance with manufacturer’s instructions. Apply epoxy primer to dry edge. Touch up with helicopter paint color, where applicable, is optional.

**Kit Instructions (continued)**

12. Refer to Images 1, 2, & 3. Loop one end of a 12-inch length of (minimum) .032 inch safety wire. Thread safety wire thru small hole of F955-4 stiffener assembly as shown in Image 1. Insert free end of safety wire in 0.75 inch diameter hole of tailcone skin, and out thru rivet hole as shown in Image 2. Position stiffener inside tailcone, matching holes in tailcone to holes in stiffener. Repeat process for second stiffener assembly.
13. Refer to Image 4. Position doubler as marked in step 10 with safety wire threaded thru matching rivet holes of doubler. Align holes of stiffeners, tailcone, and doubler. Install clecos thru holes of doubler that align with lower holes of stiffeners. Temporarily secure doubler and stiffeners to tailcone using (2) NAS6604-3 bolts & (4) NAS1149F0432P washers ([2] washers per bolt); snug bolts hand tight. Remove safety wire. Install clecos in all remaining holes in doubler. Perform steps 12 & 13 on opposite side of tailcone.
14. Refer to Figure 7. Install stiffeners and doubler to tailcone skin using (4) NAS9301B-5-04 rivets thru stiffeners, and (14) NAS9301B-5-02 rivets thru doublers, each side of tailcone as shown, removing clecos one at a time as required. Inspect installed rivets per manufacturers' specifications at: [CA-1015.pdf \(cherryaerospace.com\)](#). Remove bolts & washers.
15. Refer to Figure 8. Using hardware provided in kit, install one MT830-3 plate to each side of tailcone, and attach F955-6 bracket (apex forward as shown in Figure 9) to plates.
16. Refer to Figure 9. Using hole finder and #30 drill fitted with drill stop, locate holes in tailcone and progressively match drill & cleco (4) holes thru F955-6 bracket. Enlarge holes in bracket & tailcone to 0.156-0.164 inch diameter using #21 drill fitted with drill stop. Temporarily attach MT830-4 template to bracket & tailcone using clecos. Drill 0.156-0.164 inch diameter center hole thru template, bracket & tailcone. Repeat process in 2nd position. Remove MT830-4 template, MT830-3 plate, and F955-6 bracket. Deburr holes & clean up debris. At installer's discretion, chemically treat and/or prime/paint hole edges as described in NOTE in step 11.
17. Refer to Figures 7 & 10. Apply B270-1 sealant around F955-2 doublers as shown in Figure 7. Apply a small bead of B270-1 sealant around the three rivet holes in F955-6 bracket (two places), as shown in Figure 10.
18. Install F955-6 bracket (with apex forward) using six clecos. Replace clecos, one at a time, with NAS9301B-5-03 rivets. Inspect installed rivets per manufacturers' specifications at: [CA-1015.pdf \(cherryaerospace.com\)](#).
19. Refer to Illustrated Parts Catalog (IPC) Figure 53-45. While supporting F050-2 horizontal stabilizer assembly, secure stabilizer to tailcone using (4) NAS6604-3 bolts and (4) NAS1149F0432P washers. Secure stabilizer to F955-6 bracket using (4) NAS6603-2 bolts, (8) NAS1149F0332P washers, and (4) D210-3 nuts. Special torque hardware per MM § 23-33, and torque stripe per MM Figure 2-1.
20. Install strobe light, if removed. Install tailcone inspection plugs.

**Kit Instructions (continued)**

21. Refer to IPC Figure 53-37. Install F044-1 vertical stabilizers mount assembly per MM § 4.630 using (2) NAS6606-47 bolts, (2) NAS1149F0632P washer under head, (2) D210-6 nuts, (A/R) NAS1149F0663P under nut, & (2) B330-19 palnuts. Install tail light per MM § 26-12. Do not install D301 empennage ballast weight (if previously installed) until helicopter weight & center of gravity (CG) is determined in step 28.
22. Install C042-1 upper vertical stabilizer per MM § 4.610.
23. Install C043-1 lower vertical stabilizer per MM § 4.620. Install C050-2 float stabilizer assembly per MM § 4.700, as applicable.
24. Install D079-1 guard assembly per MM § 4.400.
25. Refer to Figure 11. Install A654-3 decal to both sides of tailcone in location shown, per MM § 21-10.
26. Install B900-15 component modification plate adjacent to existing C023-XX (tailcone) identification plate.
27. Touch-up paint, as required. Factory paint codes are located in the Aircraft Maintenance Records.
28. Weigh helicopter per MM § 18-20, installing ballast as required. Revise helicopter's Weight and Balance Record in Pilot's Operating Handbook (POH) Section 6.

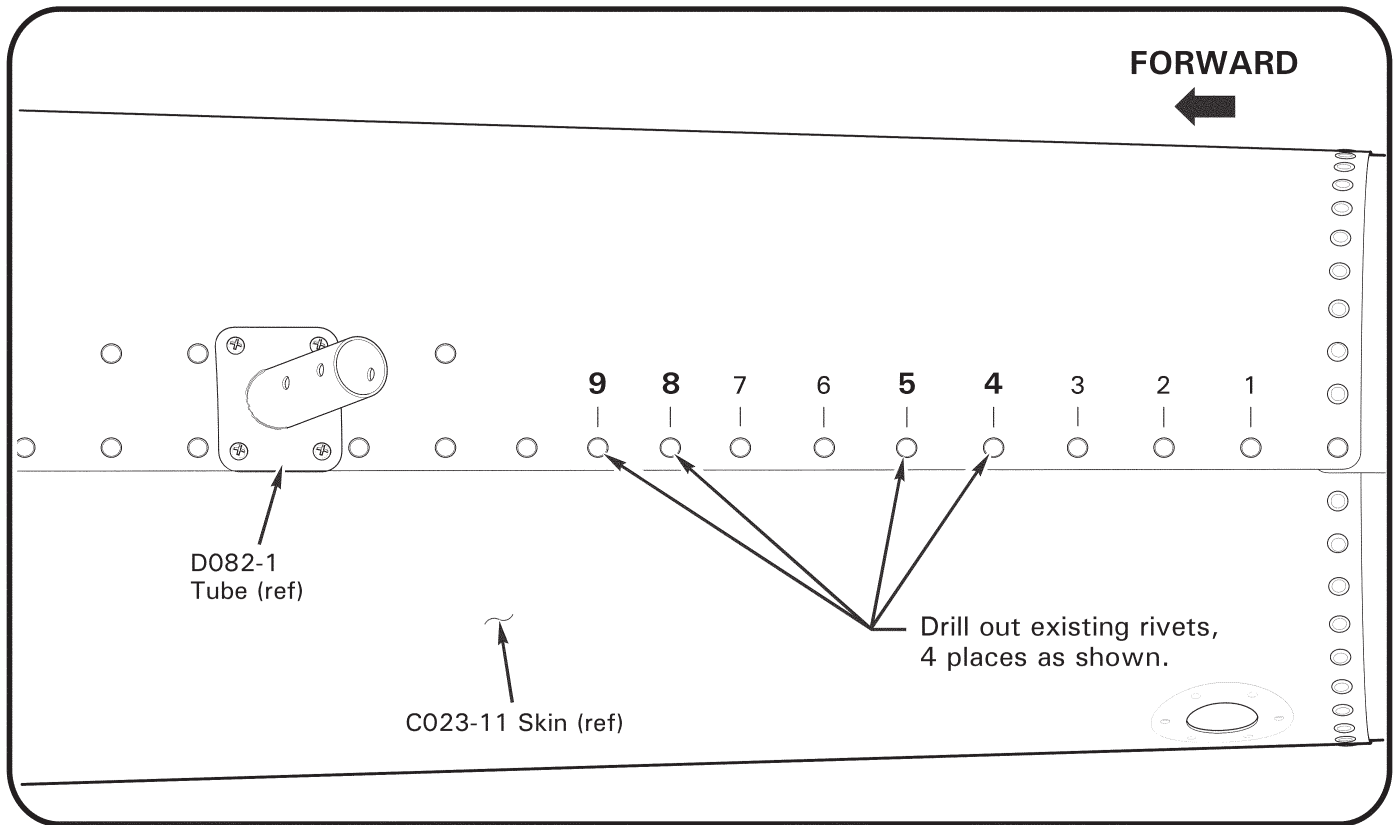
**NOTE**

Remove nose ballast before adding empennage ballast.

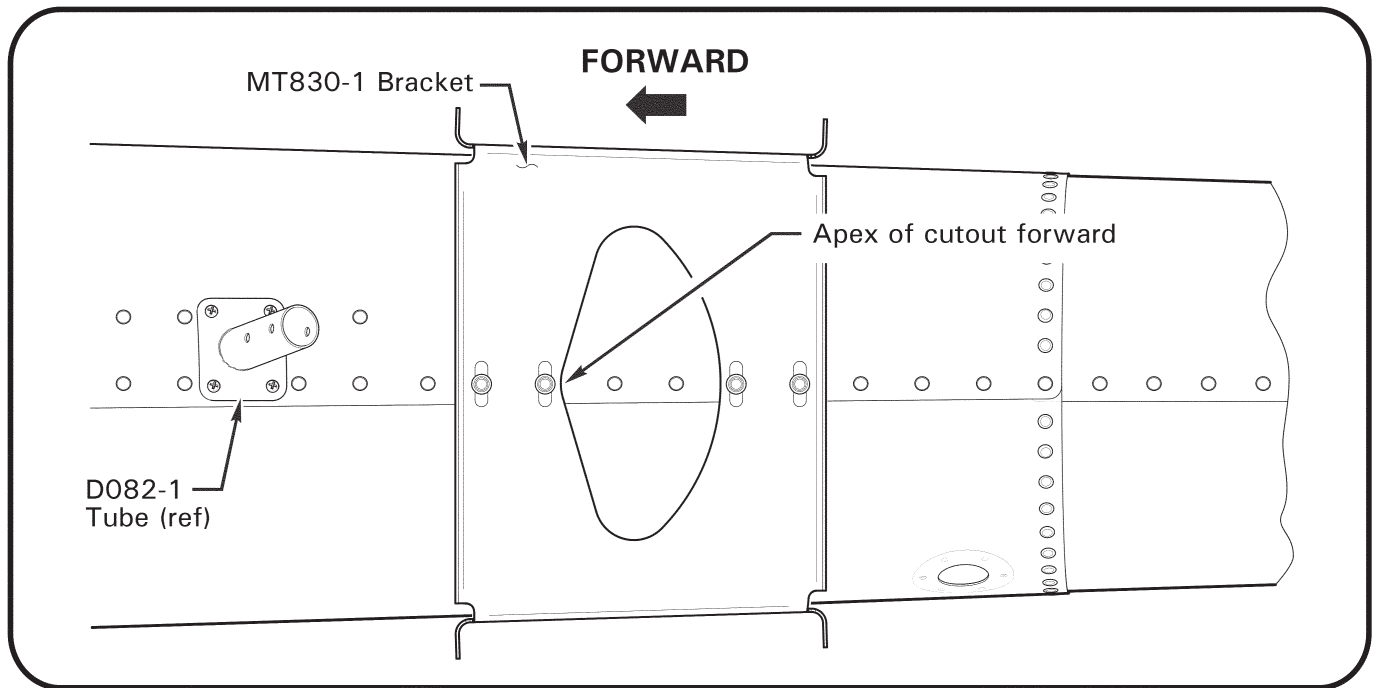
**NOTE**

Component Record (RF 294), required for F050-2 horizontal stabilizer assembly, is printable from our website. Go to: [https://robinsonheli.com/Custom Support/Maintenance Record](https://robinsonheli.com/Custom%20Support/Maintenance%20Record). Refer to MM § 3.300 Airworthiness Limitations for horizontal stabilizer life limit.

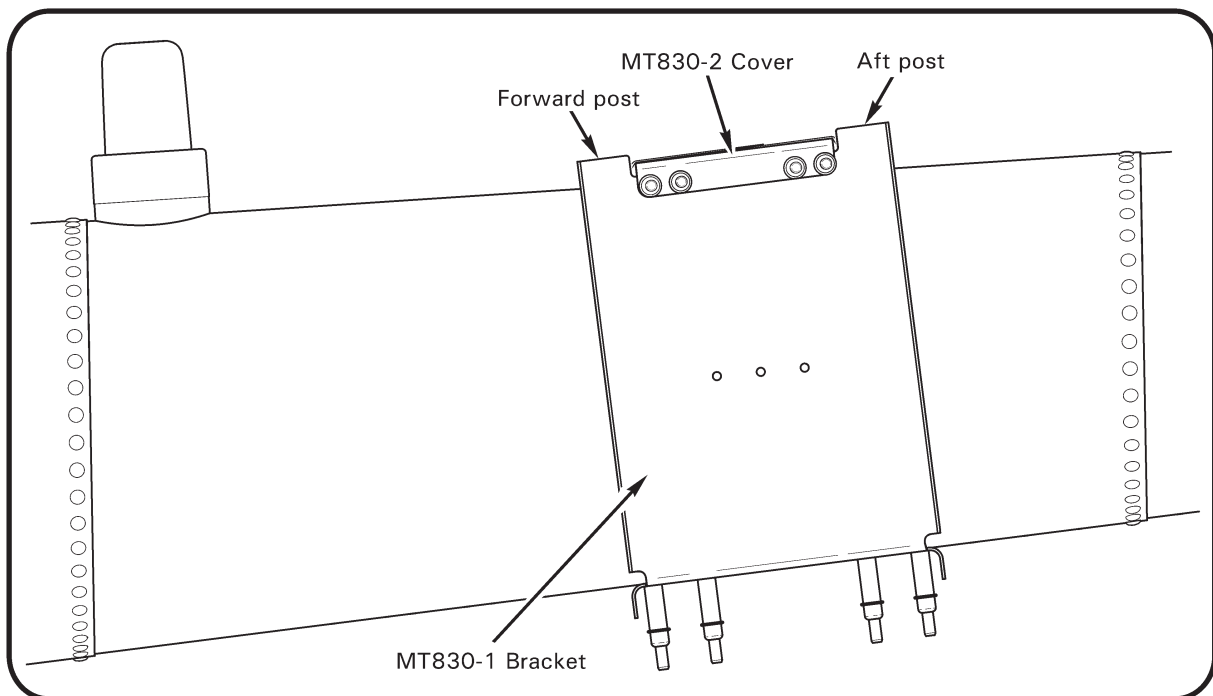
29. Make appropriate maintenance record entries.



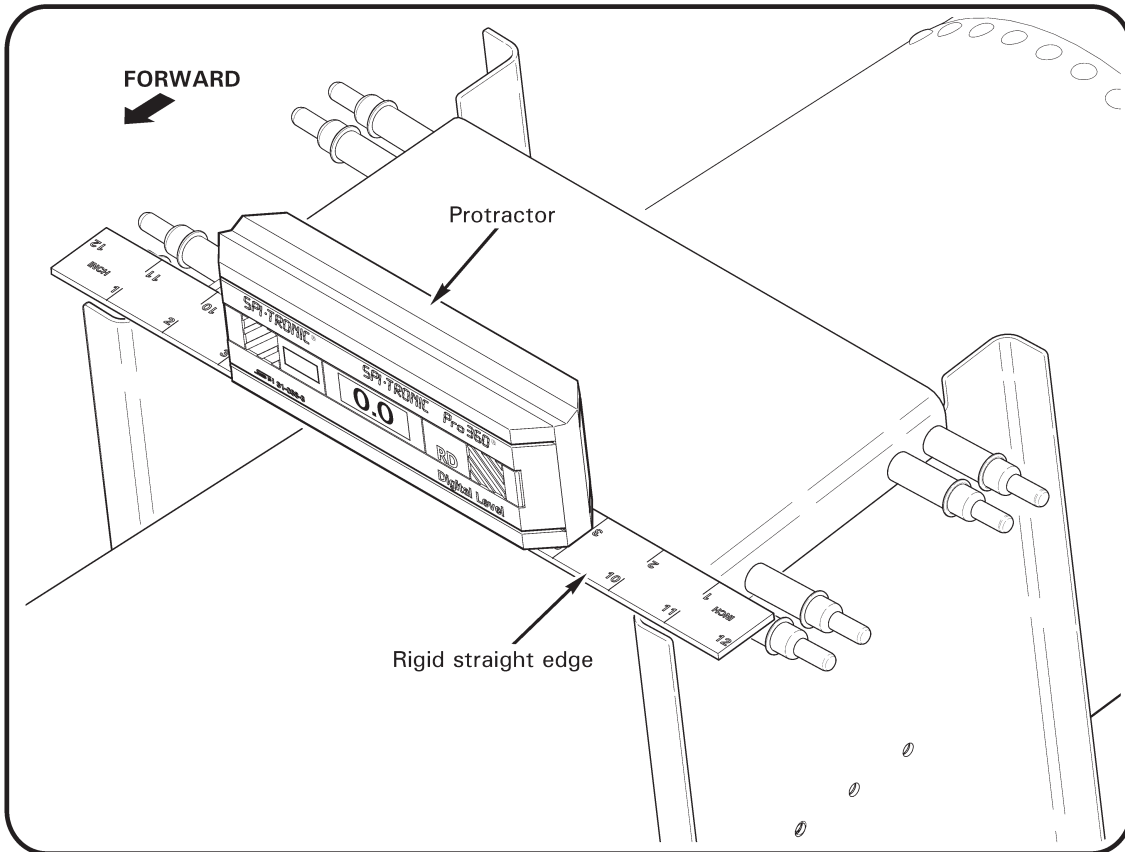
**FIGURE 1 Locate & remove tailcone rivets**  
(tailcone bottom, view looking up)



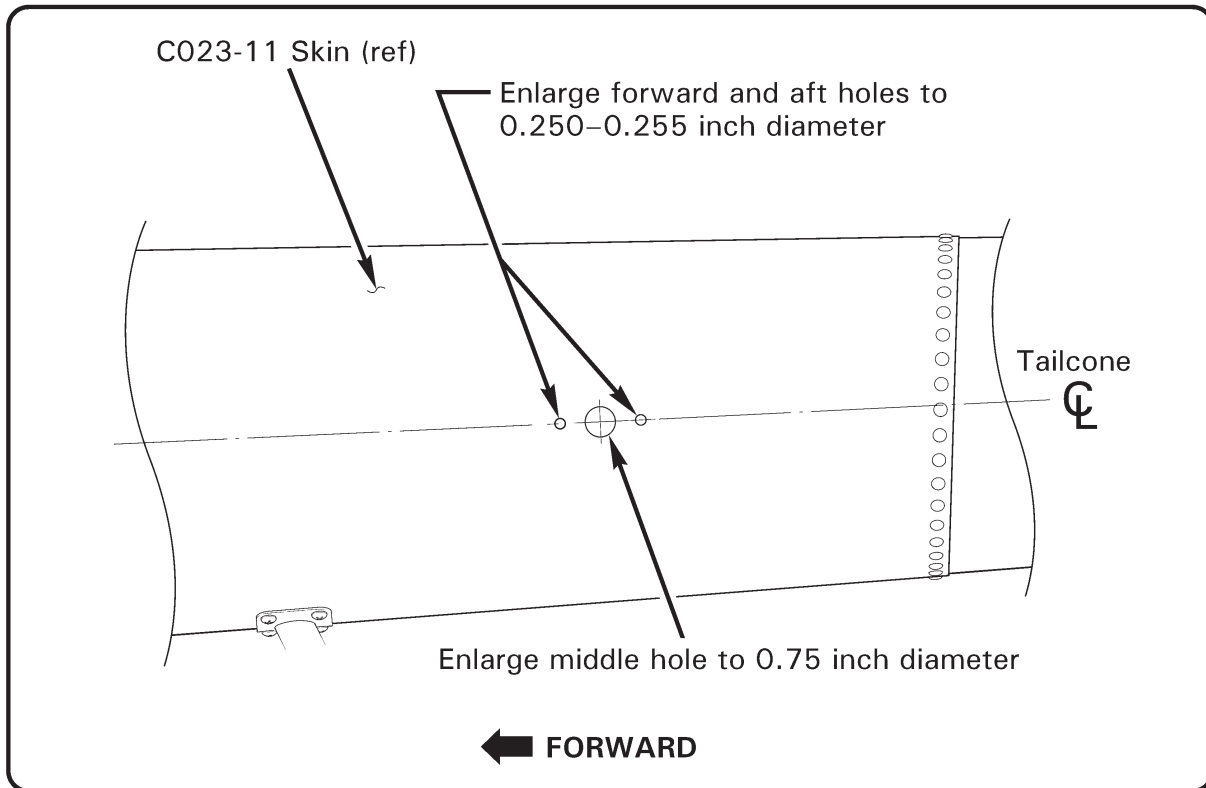
**FIGURE 2 Position MT830 bracket**  
(tailcone bottom, view looking up)



**FIGURE 3 Assembling MT830 Locator tool**

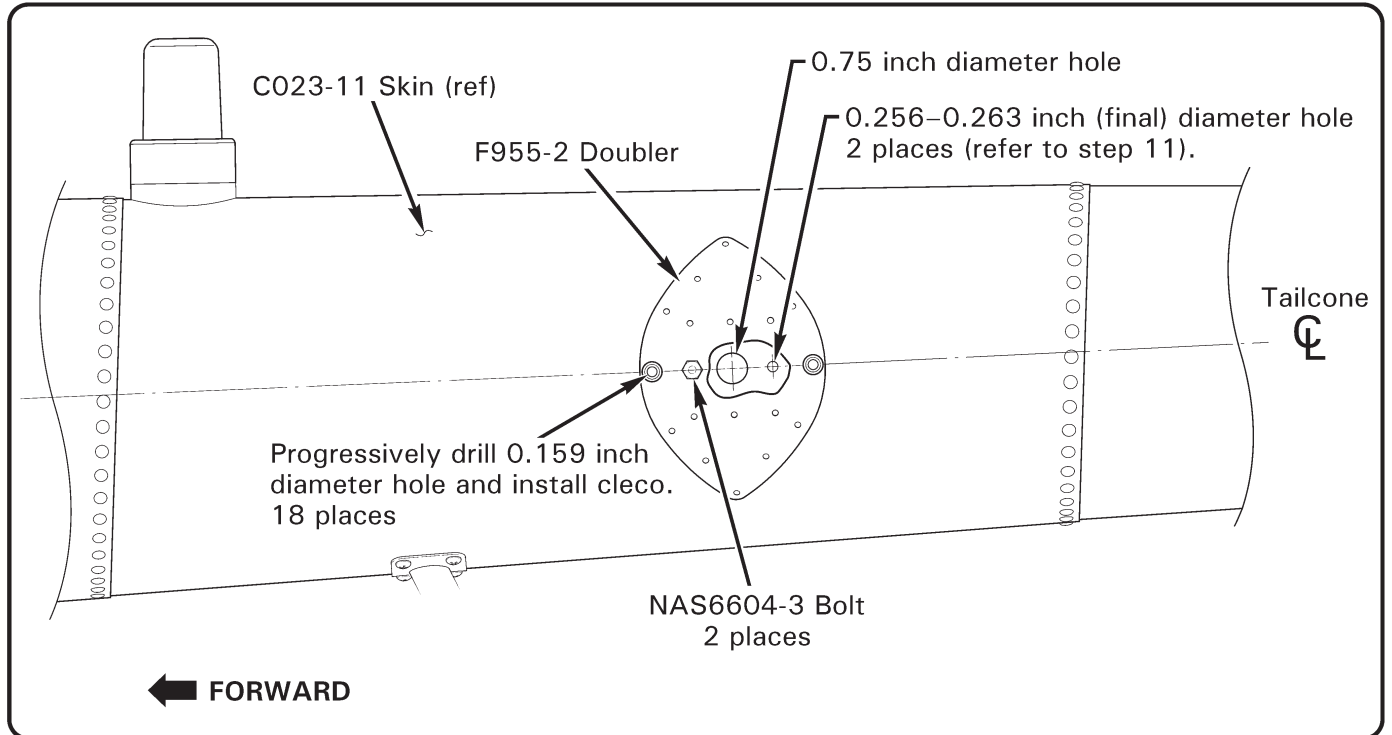


**FIGURE 4** Leveling MT830 Locator tool

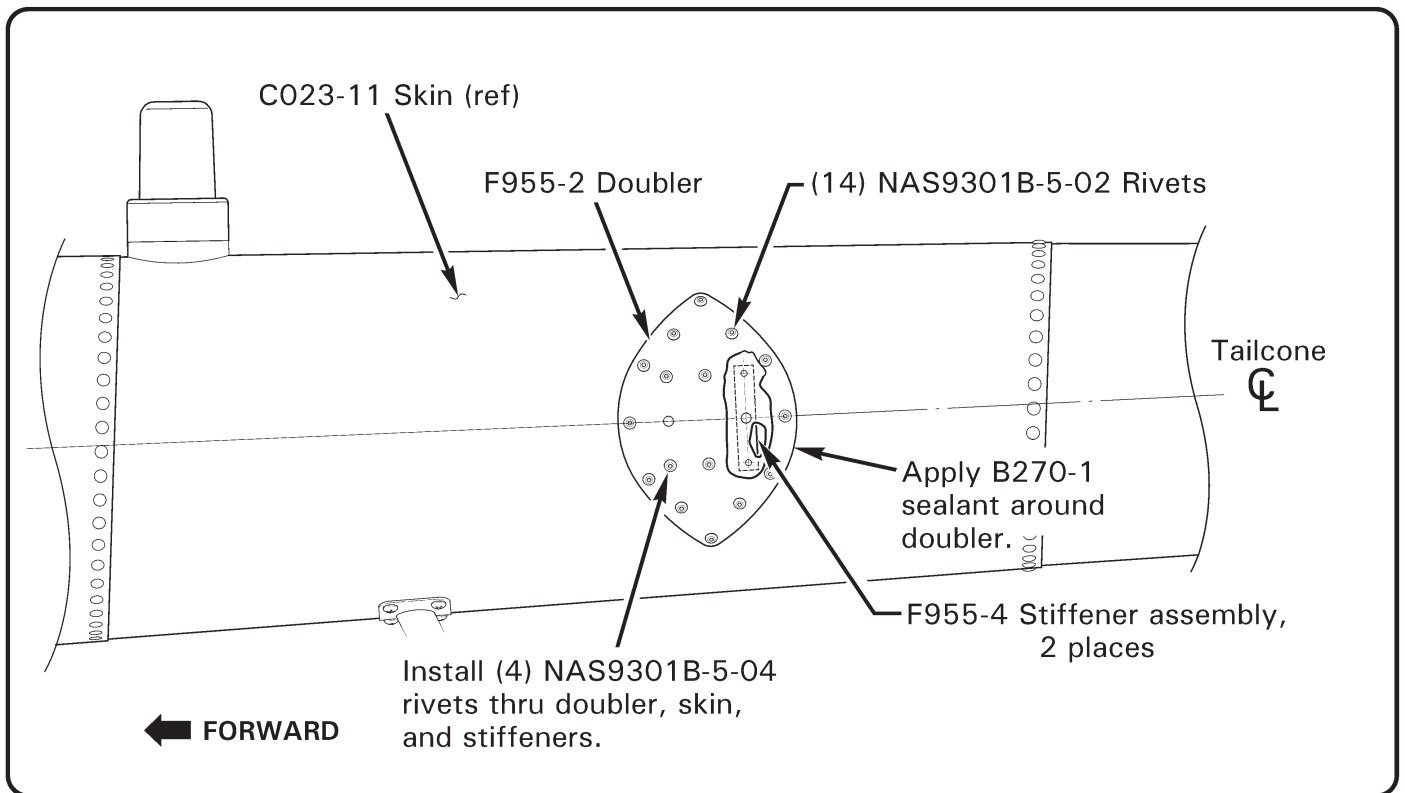


**FIGURE 5** Holes for stiffener installation  
(LH side shown, RH side similar)

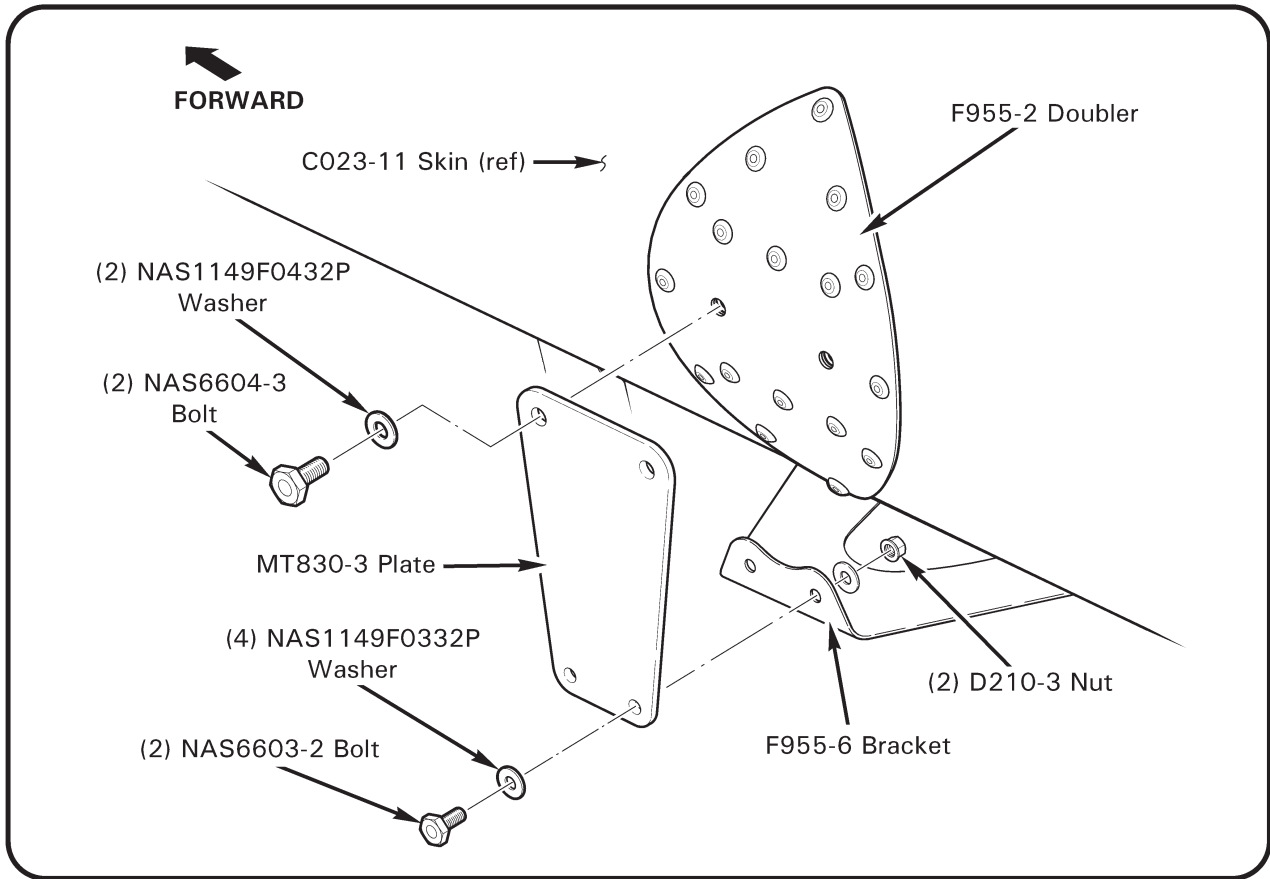




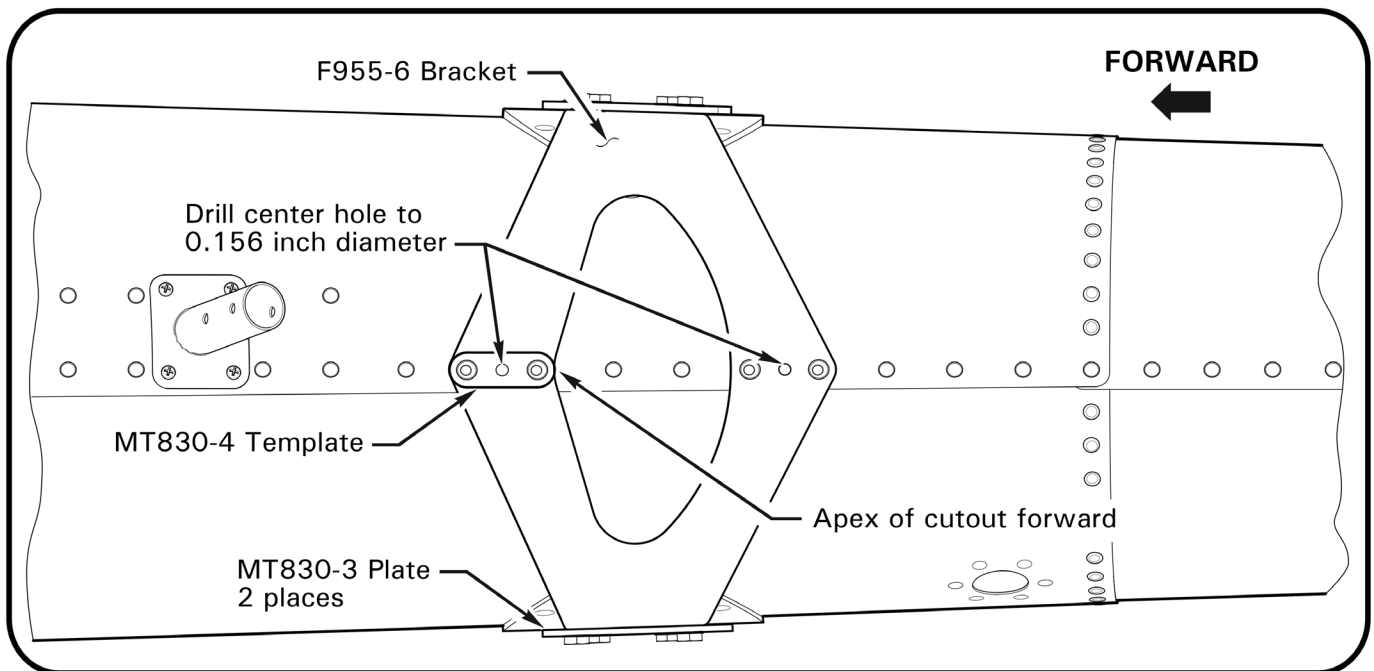
**FIGURE 6 Positioning doubler for drilling**  
(LH side shown, RH side similar)



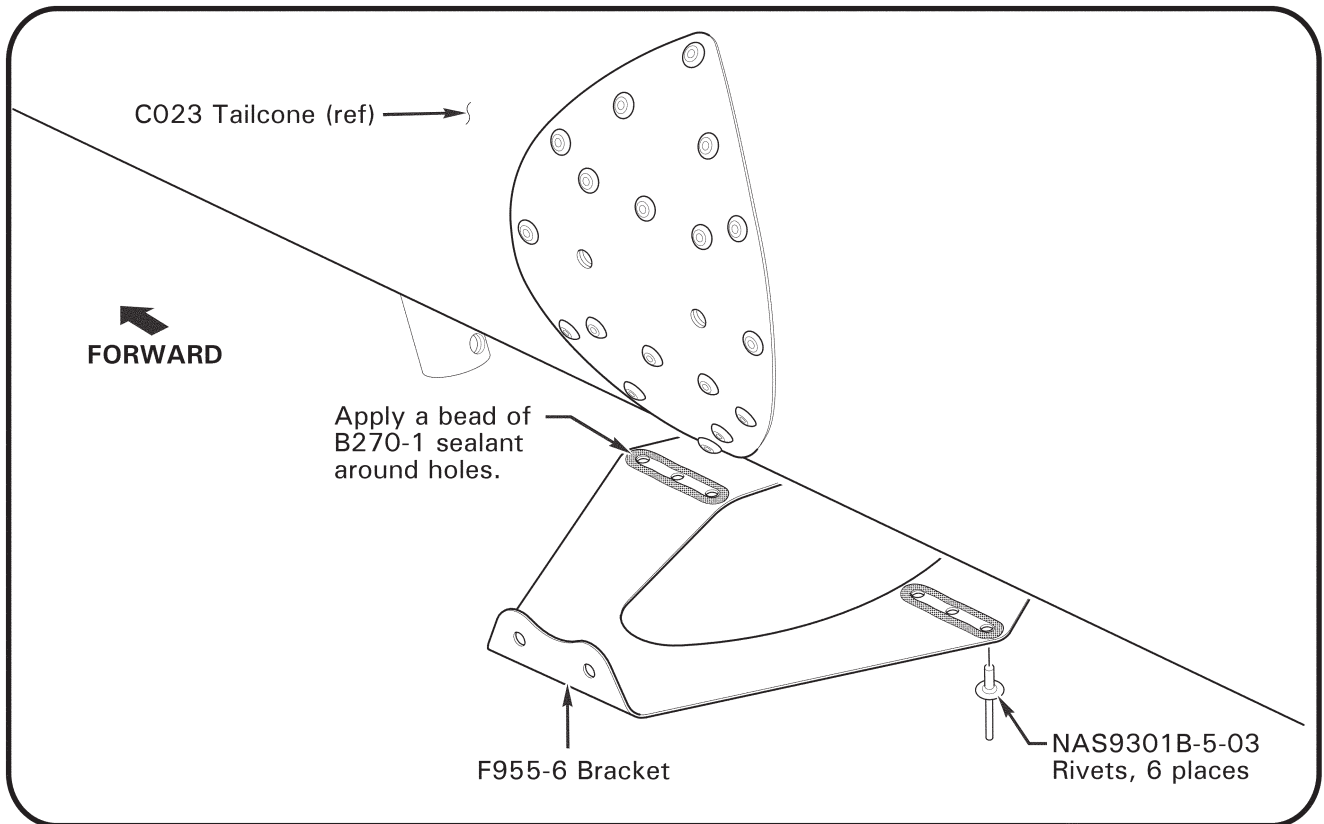
**FIGURE 7 Doubler & stiffener assembly installation**  
(LH side shown, RH side similar)



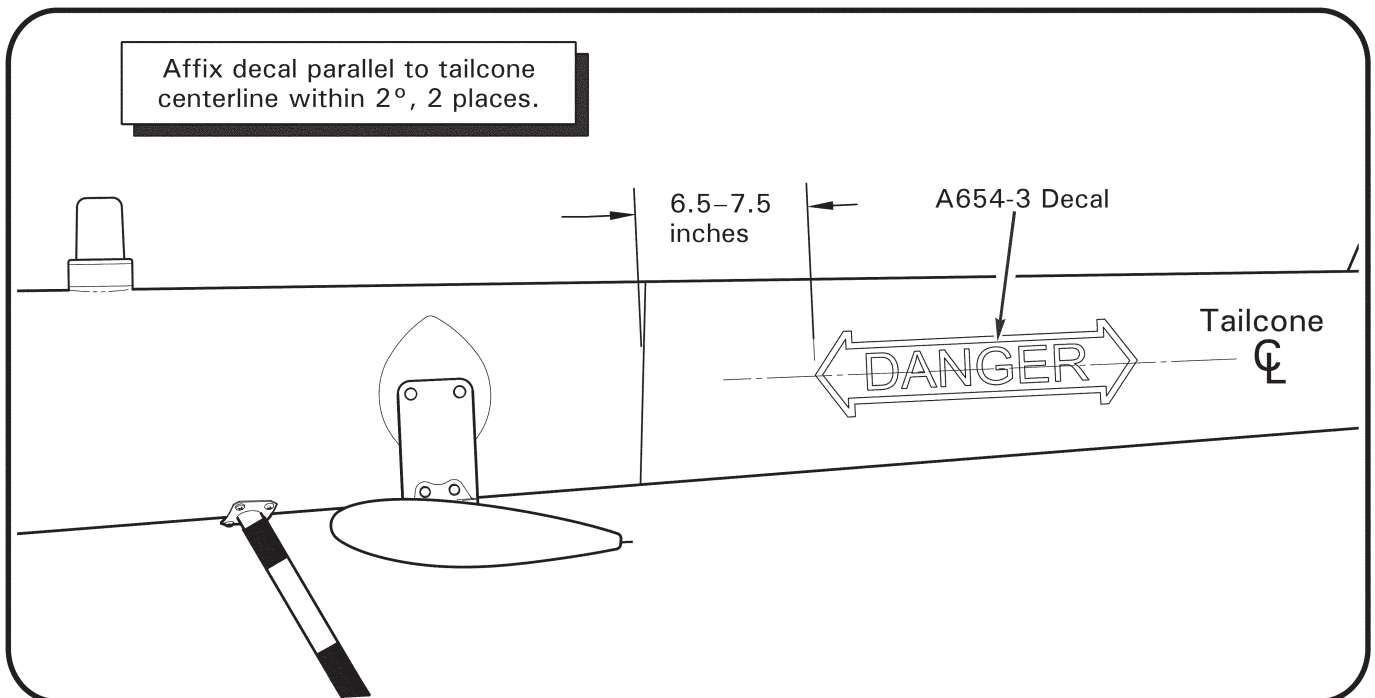
**FIGURE 8 MT830-3 plate installation**  
(LH side shown; RH side similar)



**FIGURE 9 Drilling of F955-6 bracket**  
(view looking up)



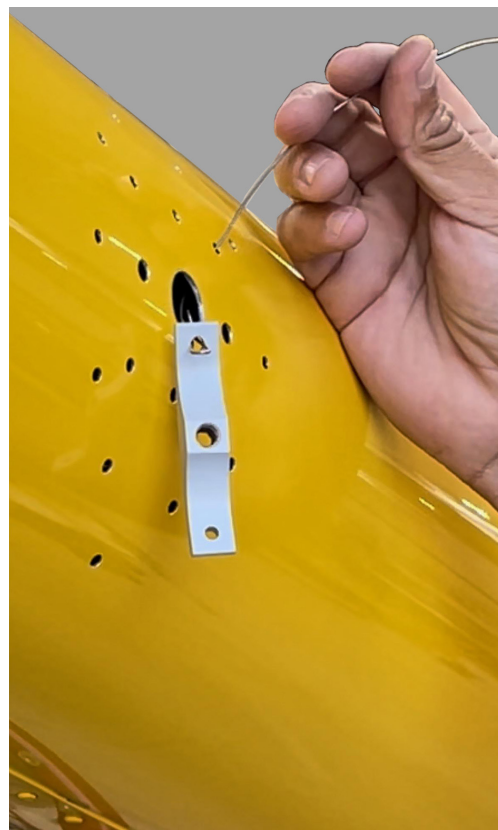
**FIGURE 10 F955-6 bracket installation**  
(application of B270-1 sealant; view looking up)



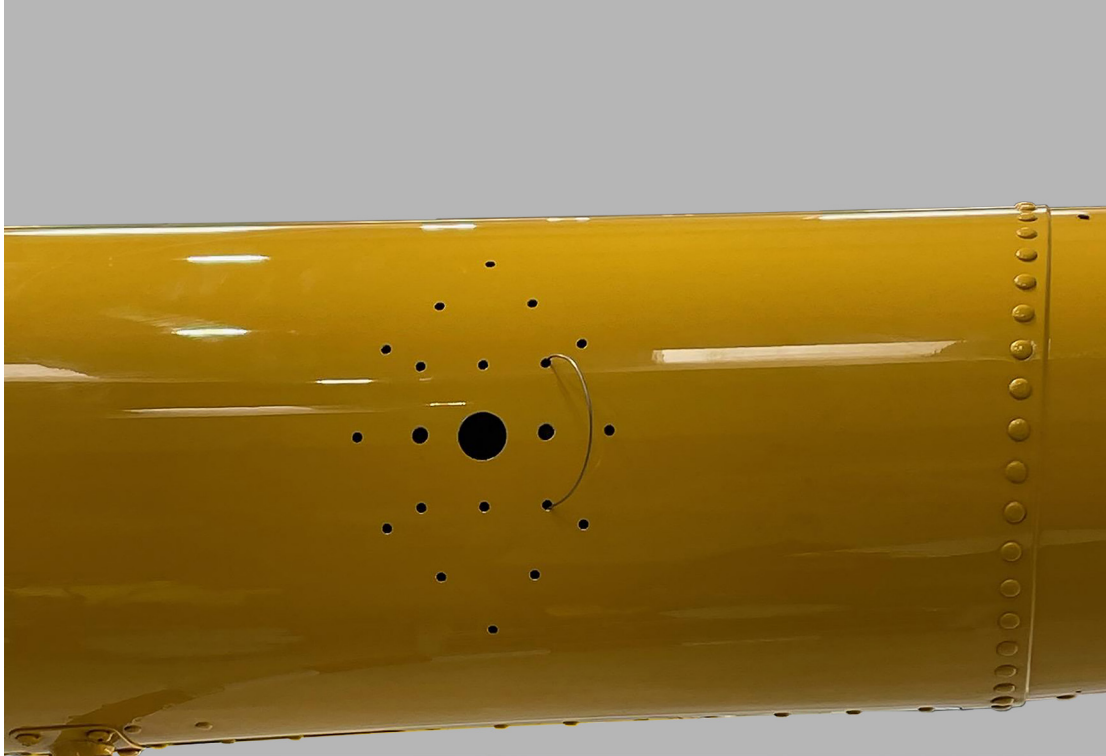
**FIGURE 11 A654-3 decal installation**  
(LH side shown, RH side similar)



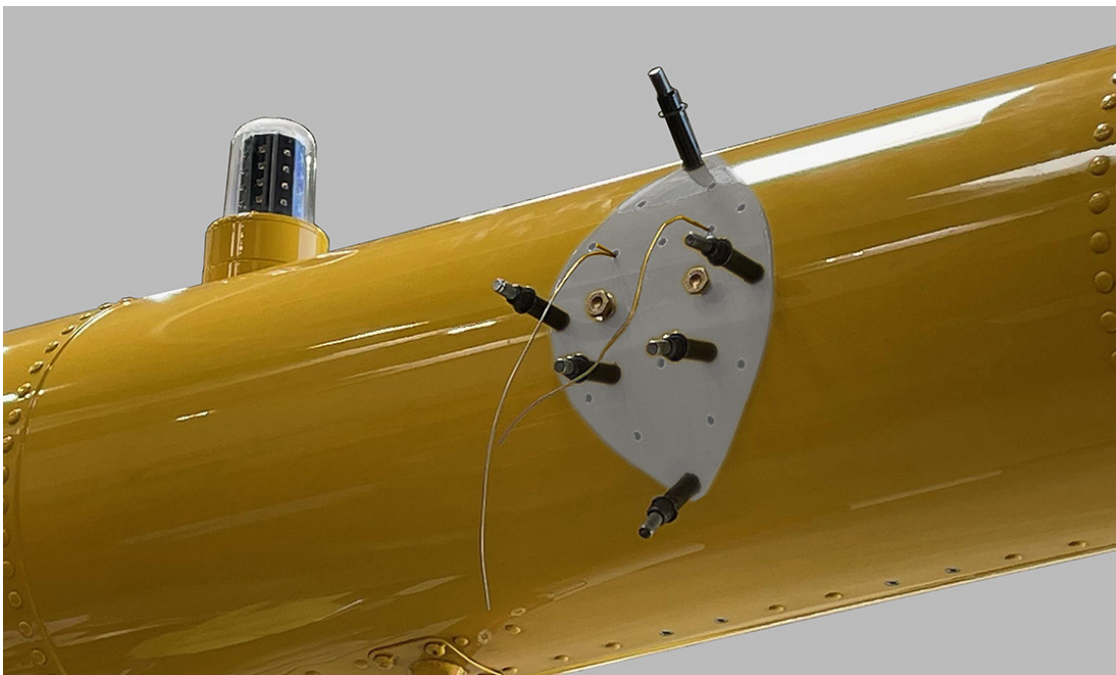
**IMAGE 1 F955-4 stiffener & safety wire loop**  
(shown with .040 inch thick safety wire)



**IMAGE 2 Installing F955-4 stiffener**  
(RH side shown; LH side similar)



**IMAGE 3 F955-4 stiffener in position**  
(LH side shown; RH side similar)



**IMAGE 4 Holding F955-4 stiffener & F955-2 doubler in position**  
(LH side shown; RH side similar)