

R44-series (28V only) External Power Plug Installation Kit Instructions
For R44-series (28V) with aft battery (engine compartment) installation only.

NOTE

Visit www.robinsonheli.com to verify kit instructions are current revision. Review instructions before installation; contact RHC Technical Support with questions. Verify kit contents match list; contact RHC Customer Service if parts are missing or damaged.

ITEM	PART NUMBER	KIT CONTENTS	QTY
1	KI-213-1Instr.	Kit Instructions	1
2	A448-17	Bus Bar	1
3	A780-61	Cable Assembly (marked "-1991").	1
4	A780-77	Cable Assembly (high temperature wire) Includes: [1] B274-704 Wire (marked "-1970") [1] B270-712 Wire [1] B270-712 Wire (marked "-2324") [1] B270-718 Wire (marked "-2055")	1
5	B158-16-1FT	Heat Shrink – 1 inch diameter (12 inch length)	1
6	B263-3	Pin	3
7	B297-20	Circuit Breaker (20 amp)	1
8	B304-13	Diode Assembly	1
9	B415-2	Relay – 28V	1
10	C452-5	Guard	1
11	D033-2242A	Wire Assembly (marked "-2242") Includes: [1] B260-12 Terminal [1] B260-14 Terminal [1] B274-712 Wire (high temperature, 12 gage, 12 inch length)	1
12	D210-3	Nut	3
13	D210-4	Nut	1
14	D420-1	Block	2
15	D420-4	Block Assembly	2
16	G597-6	Receptacle Assembly	1
17	G598-2	Faceplate	1
18	KI-213-3	Wire Assembly (marked "-1964") Includes: [1] B263-2 Socket [1] B263-31 Housing [1] B274-20 Wire (unshielded, 20 gage, 13.5 inch length)	1
19	STPS80H100TV	Rectifier	1
20	AN4-3A	Bolt	1

ITEM	PART NUMBER	KIT CONTENTS (Cont'd)	QTY
21	MS21042L06	Nut	2
22	MS21042L08	Nut	2
23	MS21919WDG5	Clamp	1
24	MS21919WDG6	Clamp	1
25	MS21919WDG8	Clamp	1
26	MS21919WDG9	Clamp	1
27	MS21919WDG10	Clamp	1
28	MS21919WDG14	Clamp	1
29	MS21919WDG16	Clamp	1
30	MS25171-2S	Nipple	2
31	MS27039C0807	Screw	2
32	MS27039C1-06	Screw	1
33	MS27039C1-08	Screw	1
34	MS27039C1-14	Screw	2
35	MS3367-5-9+	Ty-rap (Note: "+" in contents part number indicates 20-qty pack)	2
36	MS35206-228+	Screw (Note: "+" in contents part number indicates 10-qty pack)	1
37	NAS1149F0332P+	Washer (Note: "+" in contents part number indicates 20-qty pack)	1
38	NAS1149F0432P+	Washer (Note: "+" in contents part number indicates 20-qty pack)	1
39	NAS1149FN616P+	Washer (Note: "+" in contents part number indicates 20-qty pack)	1
40	NAS1149FN816P+	Washer (Note: "+" in contents part number indicates 20-qty pack)	1
41	NAS6603-16	Bolt	4

Consumables

- Scotch-Brite or similar gentle abrasive product

Special Tools:

- Drilling and deburring tools
- Cobalt steel drill bits, sizes #11 & #28
- Wire stripping and pin crimping tools
- Electrical pin extractor

Kit Instructions

CAUTION

To minimize risk of electrical discharge: When disconnecting battery, disconnect negative (ground) cable from the battery first, then disconnect positive cable. When connecting battery, connect positive cable first, then connect negative (ground) cable.

1. Turn BATTERY switch OFF. Disconnect lead-acid battery per R44 Maintenance Manual (MM) § 37-10 or lithium-ion battery per MM § 37-12, as applicable.

Kit Instructions (continued)

2. Refer to R44 Illustrated Parts Catalog (IPC) Figures 6-11, 6-13, 25-1, 28-1 & 53-1. Remove C377 and C378 engine cowling assemblies, and C794-3 aft belly panel. Remove C474-1 and C474-2 aft tunnel covers, C474-3 trim, and F936-2 or C932-2 aft left backrest.
3. If helicopter is equipped with blind encoder, refer to IPC Figures 97-29, 97-33 or 97-45. Cut and discard ty-raps securing wire bundles and pitot/static lines to bulkhead stiffeners as required. Remove & retain mounting hardware and move blind encoder away from bulkhead.
4. Refer to Figure 1. Remove & retain hardware securing cables to B415-2 (battery) relay contactor terminals (inboard and outboard).

NOTE

Remove foam as required from cabin bulkhead to access relay and rectifier mounting hardware.

5. Refer to Figure 2. Lay out hole locations on vertical, stainless steel firewall for STPS80H100TV rectifier and B415-2 (external power) relay. Using cobalt steel bits with drill-stops, drill a series of pilot holes, then drill to final size: (1) 0.190-0.196 inch diameter hole (relay), and (2) 0.140-0.146 inch diameter holes (rectifier). Deburr holes and clean up debris.
6. Install hardware and secure rectifier, with slot inboard, to firewall.
7. Remove (battery) relay inboard mounting fastener and discard screw. Install hardware and secure C452-5 guard (direction of overlap is optional) and (external power) relay (direction of overlap is optional) to firewall. Verify security of guards and relays.
8. Refer to Figure 3, Detail A. Lay out hole location on C015-4 skin. Drill one 0.256-0.263 inch diameter hole and deburr. Remove finish within a 0.5 inch diameter circle on skin interior, centered on newly-drilled hole, to ensure electrical ground when ground cable is attached. Clean up debris.
9. Refer to Figure 3. Install hardware securing two D420-1 and two D420-4 block assemblies to C046-2 (RH) frame assembly, finger tight. Install screws and secure G598-2 faceplate and G597-6 receptacle assembly to blocks.
10. Refer to Figure 4. Temporarily install C378 engine cowling & (de-energized) external power plug. Position D420 blocks for 0.50 ± 0.25 inch clearance between external power plug and cowl door's bottom and forward edges. Remove cowling. Standard torque NAS6603-16 bolts per MM § 23-32 and torque stripe per MM Figure 2-1.

NOTE

It is recommended a second person hold D420 blocks in desired position by holding external power plug, while block installation hardware is torqued.

Kit Instructions (continued)**NOTE**

Parenthetic dash numbers, such as (-2886), indicate number marked on wiring insulation (if single conductor), or jacket (if multi-conductor and/or shielded).

11. Attach A780-77 cable assembly's (12-gage, unmarked) wire and A780-77 cable assembly's (-2324) wire to B297-20 circuit breaker, one wire per terminal. Verify security. Trim a 4-inch length of B158-16-1FT and slide over circuit breaker, covering terminals and connected wires. Apply heat.
12. Install circuit breaker on faceplate and ensure locator tab engages slot. Verify security.

CAUTION

Do not apply side loads to plug pin studs when torquing nuts.

13. Refer to Figure 3. On receptacle assembly: secure 90-degree ("-") terminal of A780-61 cable assembly's (-1991) wire to aft large pin, and 90-degree ("+") terminal of A780-77 cable assembly's (-1970) wire to middle large pin; ensure cables are inboard of, and clear diagonal tube of steel frame. Special torque nuts to 75 in-lb. Secure A780-77 cable assembly's (-2055) wire to forward small pin and special torque nut to 20 in-lb. Torque stripe nuts per MM Figure 2-1.
14. Install hardware and secure A780-61 cable assembly's (-1991) wire to frame with clamps at location shown. Install hardware and secure cable to skin, standard torque bolt per MM § 23-32, and torque stripe per MM Figure 2-1.
15. Install hardware and secure A780-77 cable assembly's (-1970) wire to frame with clamps at location shown; position clamps for 0.25 inch minimum clearance between cable and intake hose.
16. Refer to Figure 2. Remove hardware and MS21919WDG clamp securing C859 or C059 harness to vertical firewall. Reinstall hardware securing C859 or C059 harness and A780-77 cable assembly's (-1970) wire to firewall with supplied MS21919WDG8, WDG9, or WDG10 clamp as required to eliminate harness play. Verify security.
17. Refer to Figure 1. Slide one MS25171-2S nipple onto A780-77 cable assembly's (-1970) wire. Install hardware securing A780-77 cable assembly's (-1970) wire to (external power) relay inboard stud and special torque nut to 80 in-lb. Torque stripe per MM Figure 2-1. Position nipple over stud. Install hardware securing A780-77 cable assembly's (-2055) wire to (external power) relay forward ("86", "+") terminal and special torque screw to 10 in-lb. Verify security.
18. Install hardware securing D033-2242A wire assembly's (-2242) large terminal and cable (removed in step 4) to battery relay outboard stud and special torque nut to 80 in-lb. Verify security. Torque stripe per MM Figure 2-1. Route other end of (-2242) wire thru nipple and position nipple over stud.
19. Refer to Figure 2. Install screw and secure D033-2242A wire assembly's (-2242) small terminal to rectifier upper outboard terminal.
20. Install screw securing A780-77 cable assembly's (-2324) wire to rectifier top inboard terminal. Verify security.

Kit Instructions (continued)

21. Refer to Figure 5. Determine if helicopter has provisional wiring: Later helicopters have a stowed (-1964) wire (connector protected with heat shrink) located on left-hand side of engine compartment vertical firewall. Perform **A** or **B** below, as necessary.

A. For helicopters with stowed (-1964) wire: Refer to Figures 1 and 6. Discard KI-213-3 wire assembly. Connect B304-13 diode assembly to (-1964) wire. Install hardware securing diode's ring terminal to (external power) relay aft ("-", "85") terminal and special torque screw to 10 in-lb. Verify security.

Refer to Figure 1. Position A448-17 bus bar on (battery) relay inboard stud and (external power) relay outboard stud. Install hardware securing bus bar and cable (removed in step 4) to (battery) relay inboard stud. Install hardware securing bus bar to (external power) relay outboard stud. Special torque nuts to 80 in-lb and torque stripe per MM Figure 2-1.

B. For helicopters without stowed (-1964) wire: Refer to Figures 1 and 7. Strip end of KI-213-3 wire assembly's (-1964) wire and crimp B263-3 pin on wire. Inspect crimp per MM § 23-84. Connect KI-213-3 wire assembly to B304-13 diode assembly at connectors. Install hardware securing diode's ring terminal to (external power) relay aft ("-", "85") terminal and special torque screw to 10 in-lb. Verify security.

Cut and discard ty-raps along airframe harness as required to locate and disconnect three-pin connector for wires (-65) and (-66). Release wire (-65)'s existing pin from housing. Cut off pin, strip wire end, and crimp B263-3 pin on wire. Perform crimp inspection per MM § 23-84. Install pin in original location in housing. Reconnect same three-pin connector. Secure wiring using appropriately-sized ty-raps as required. Cinch ty-raps until snug without overtightening and trim tips flush with heads.

Refer to Figure 1. Position A448-17 bus bar on (battery) relay inboard stud and (external power) relay outboard stud. Install hardware securing bus bar and (-581) cable to (battery) relay inboard stud. Slide one MS25171-2S nipple on (-580) cable and install cable to (external power) relay outboard stud. Special torque nuts to 80 in-lb and torque stripe per MM Figure 2-1. Position nipples over studs.

22. Secure A780-77 cable assembly to airframe harness using appropriately-sized ty-raps as required. Cinch ty-rap until snug without overtightening and trim tip flush with head.

23. Refer to Figures 6 and 7, as applicable. Verify installed wiring matches schematic.

CAUTION

Damage can occur if wiring is incorrect.

24. If helicopter is equipped with blind encoder refer to IPC Figures 97-29, 97-33 or 97-45. Install hardware securing blind encoder to cabin. Verify security. Secure wire bundles and pitot/static lines to bulkhead stiffeners using appropriately-sized ty-raps as required. Cinch ty-raps until snug without overtightening and trim tips flush with heads.

Kit Instructions (continued)

25. Functional check installation.

- a. Turn BATTERY switch OFF.
- b. Connect an external power source as indicated on receptacle faceplate.
- c. Turn BATTERY switch ON. Power should activate instruments and gages as normal.
- d. Turn BATTERY switch OFF. Disconnect external power source.

26. Connect lead-acid battery per MM § 37-10 or lithium-ion battery per MM § 37-12, as applicable.

27. Refer to IPC Figures 6-11, 6-13, 25-1, 28-1 & 53-1. Install C474-1 and C474-2 aft tunnel covers, C474-3 trim, and F936-2 or C932-2 aft left backrest. Install C377 and C378 engine cowling assemblies, and C794-3 aft belly panel.

28. Revise helicopter’s Weight & Balance Record in Pilot’s Operating Handbook (POH) Section 6 to reflect this installation by incorporating the following data:

Add:

Item	Weight	Long. Arm	Long. Moment	Lat. Arm	Lat. Moment
KI-213-1	+2.74 lb	96.39 in.	264 in-lb	+4.55 in.	12.5 in-lb

29. Make appropriate maintenance record entries.

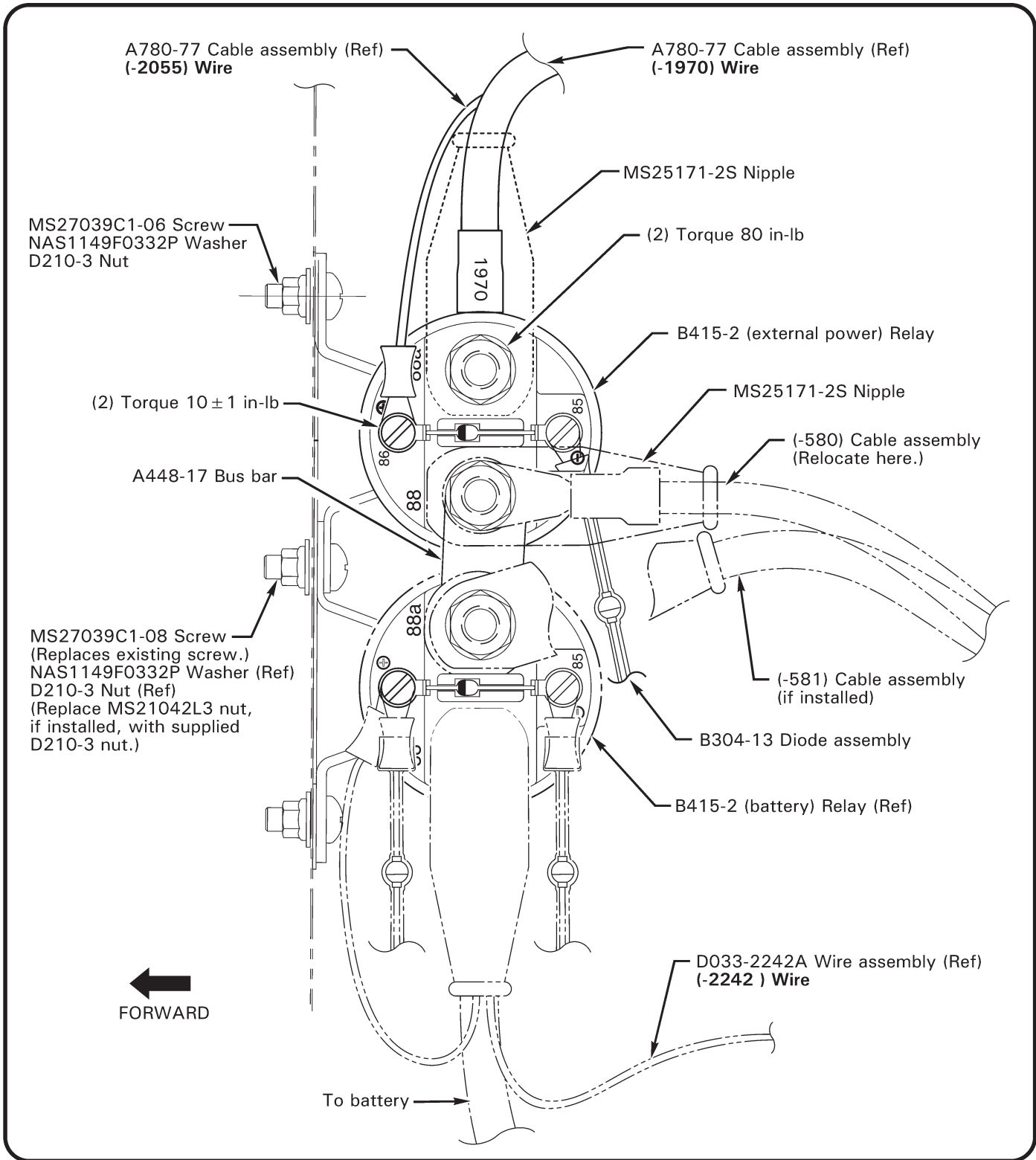

FIGURE 1
(View looking down)

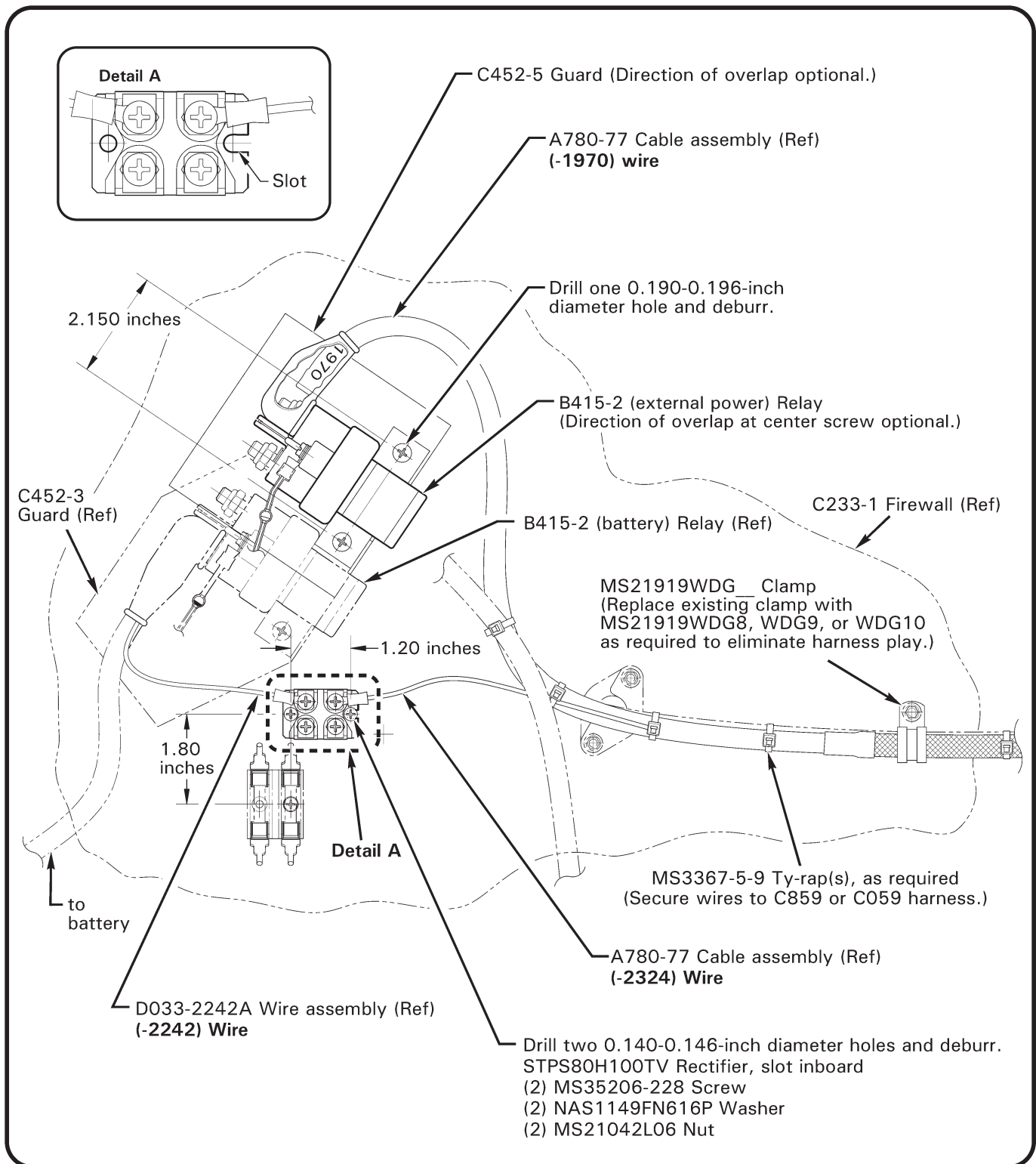

FIGURE 2
(View looking forward)

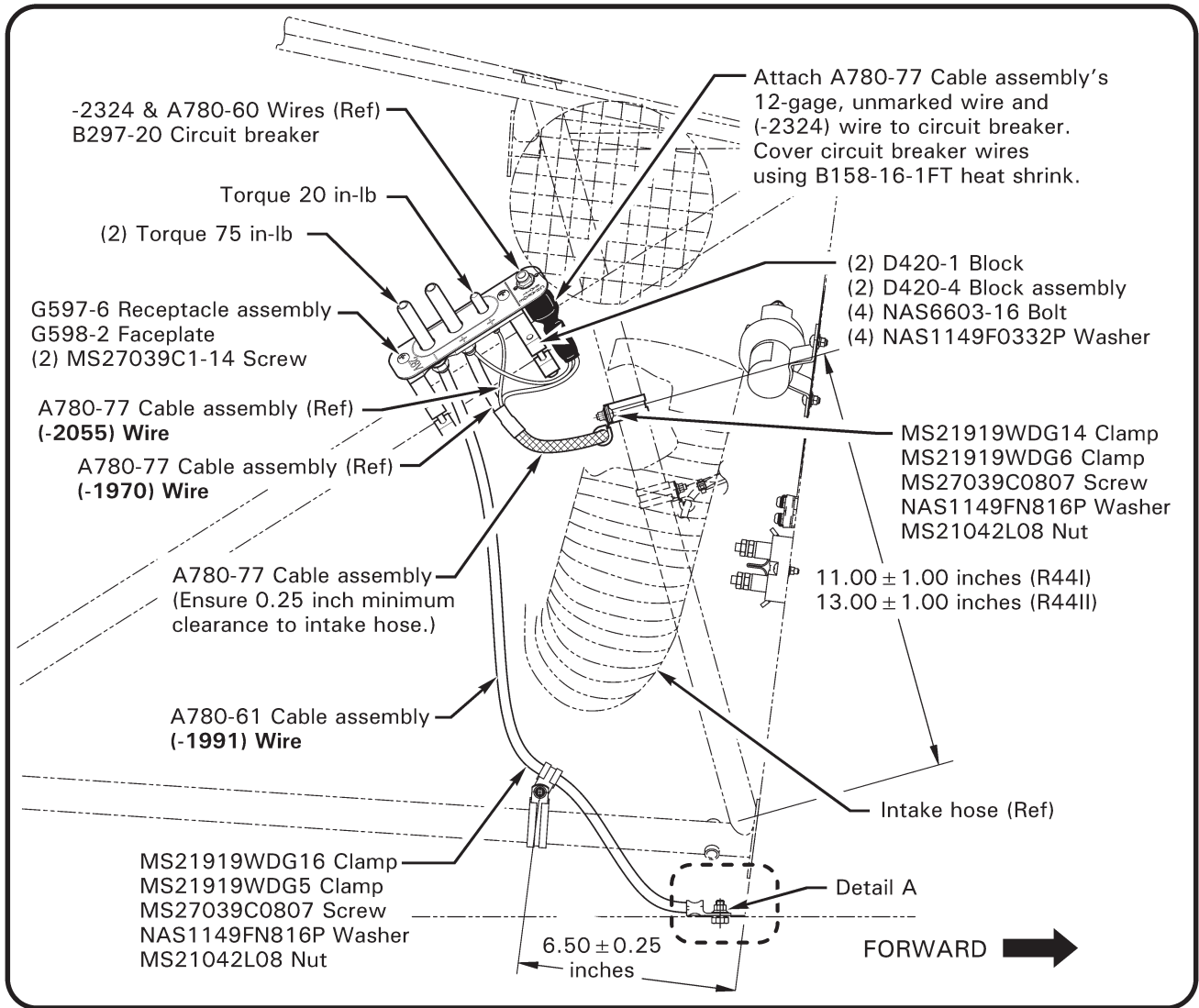
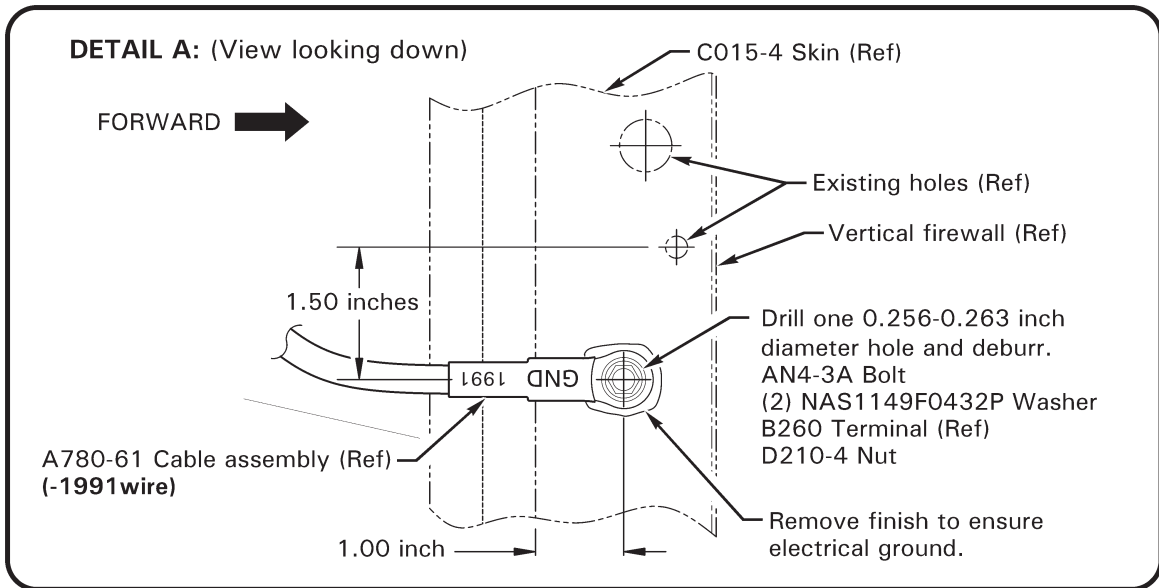

FIGURE 3
(View looking inboard from RH side)

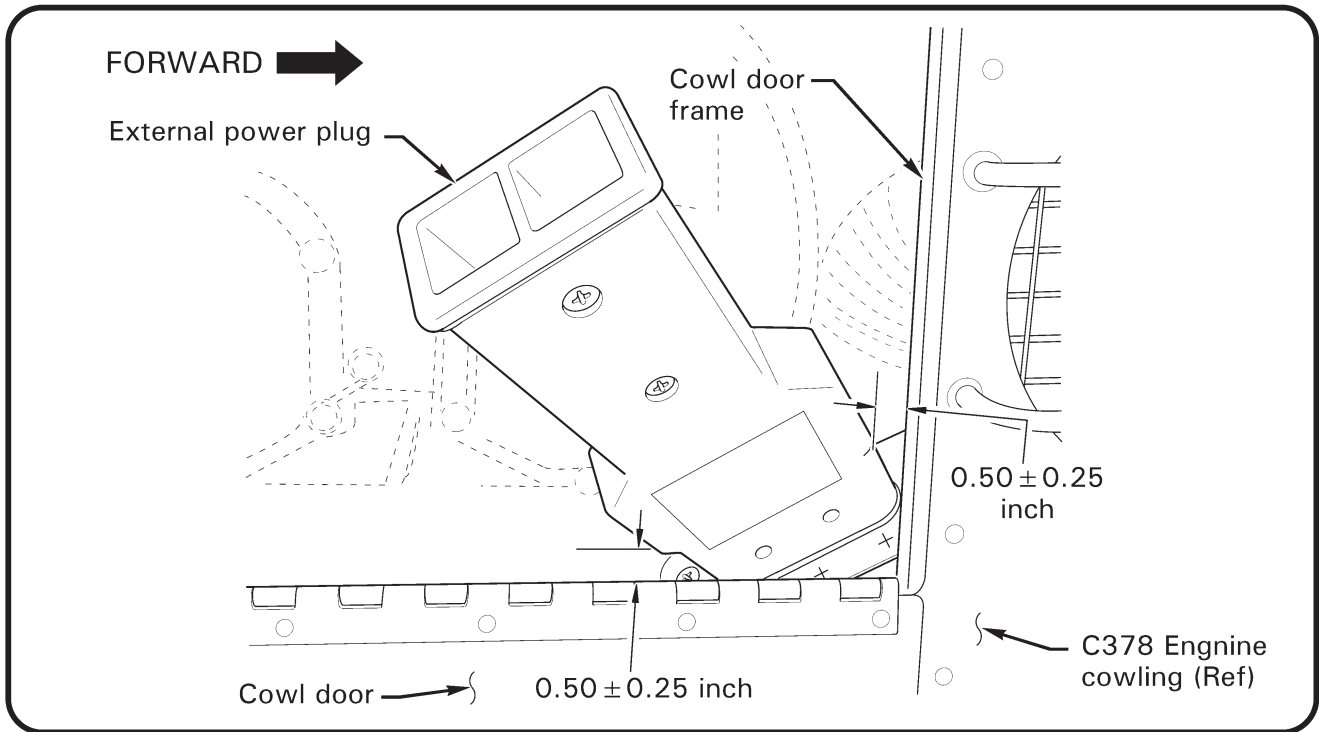

FIGURE 4

(View looking inboard from RH side, cowl door open; power plug wires not shown for clarity)

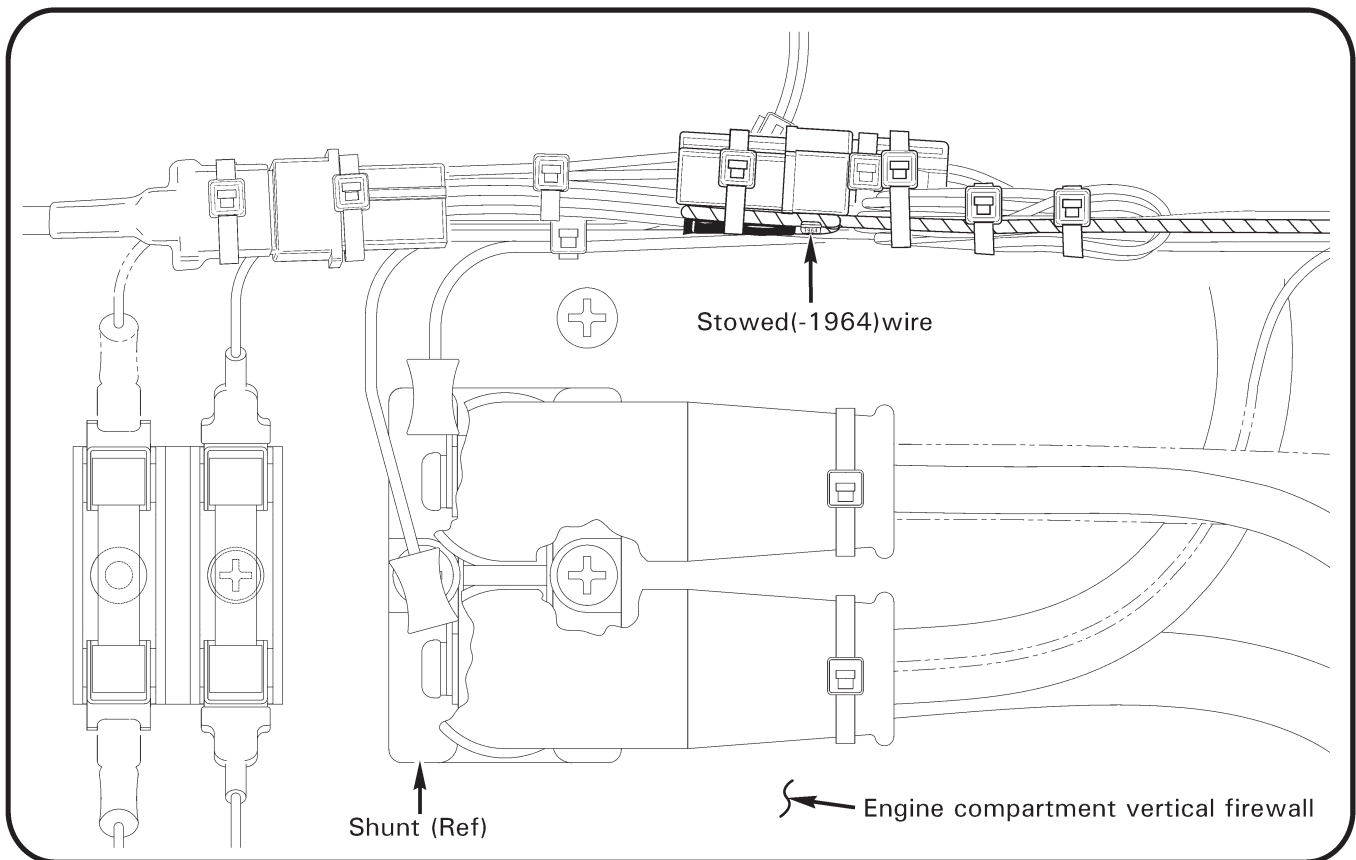

FIGURE 5 Location of provisional wiring

(Helicopter LH side, view looking forward)

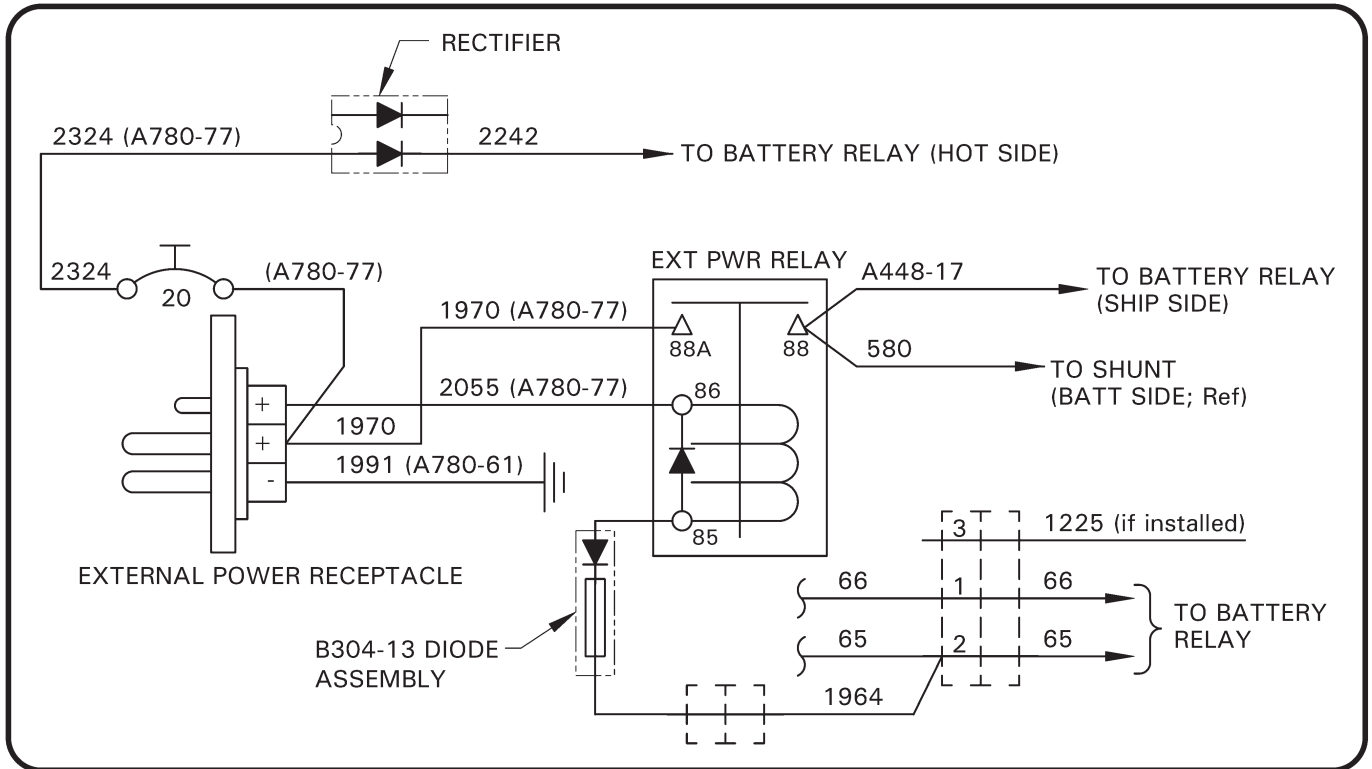

FIGURE 6 Schematic
(cabin harness with -1964 wire provision)

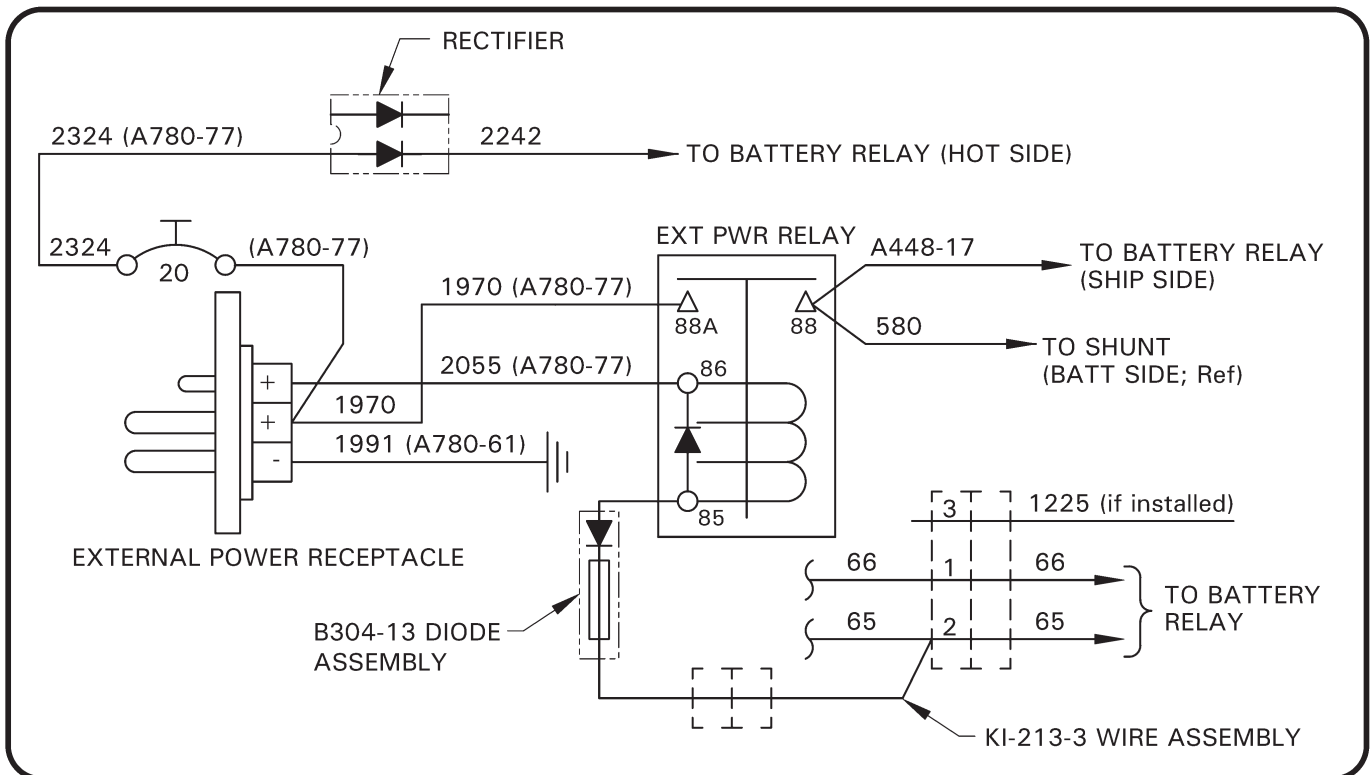

FIGURE 7 Schematic
(cabin harness without -1964 wire provision)