

R44 SERVICE BULLETIN SB-98B

(supersedes R44 SB-98A)

DATE: 15 April 2019

REV B: 3 May 2019

TO: R44-series Owners, Operators, and Maintenance Personnel

SUBJECT: Air/Oil Separator Hose Spring

EFFECTIVITY: R44 Helicopters S/N 2566 thru 2579 except 2577. R44 II Helicopters S/N 14284 thru 14314 except 14287, 14299, and 14304. R44 Cadet Helicopters S/N 30044 thru 30053 except 30047. Also helicopters retrofitted with air/oil separators.

TIME OF COMPLIANCE: Part A: Prior to further flight. Part B: Within next 5 flight hours or by 17 May 2019, whichever occurs first.

BACKGROUND: RHC has received a report of a kinked A729-75 hose, installed between the engine and C728-2 air/oil separator assembly. The kinked hose caused the crankcase to vent through the separator drain back tube, resulting in loss of engine oil. Revision A of this bulletin added an immediate inspection requirement and reduced the compliance time for installing a replacement hose and inserting a spring inside the hose to prevent kinking. Revision B adds Figures 1 & 2; compliance time is unchanged.

COMPLIANCE PROCEDURE:

Part A:

1. Open left side cowl door.
2. Refer to Figure 1. Using a bright light, visually inspect A729-75 black rubber breather hose, located above and beyond the oil filter. If hose is kinked, remove and replace prior to further flight.

Part B:

1. Refer to Figure 2. For each affected helicopter, order one D774-20 spring and one A729-75 crankcase breather hose from RHC Customer Service.
2. Remove engine RH cowling. R44 IIs only: Remove air box assembly per R44 Maintenance Manual (MM) § 6.470.
3. Remove screw securing air/oil separator's can-to-frame clamp.
4. Loosen B277-12 clamps and remove A729-75 hose; retain clamps and discard hose.
5. Install new A729-75 hose and insert new D774-20 spring inside hose; secure hose with retained clamps.

(OVER)

6. Install screw securing air/oil separator's can-to-frame clamp. Verify security.
7. Install air box assembly per MM § 6.480, if removed. Install engine RH cowling.
8. Make appropriate maintenance record entries.

APPROXIMATE COST:

Parts: No charge for one D774-20 spring and one A729-75 hose if ordered by 17 May 2019. Reference helicopter serial number when ordering.

Labor: 0.5 man-hour for R44 and R44 Cadet Helicopters.
1.0 man-hour for R44 II Helicopters.

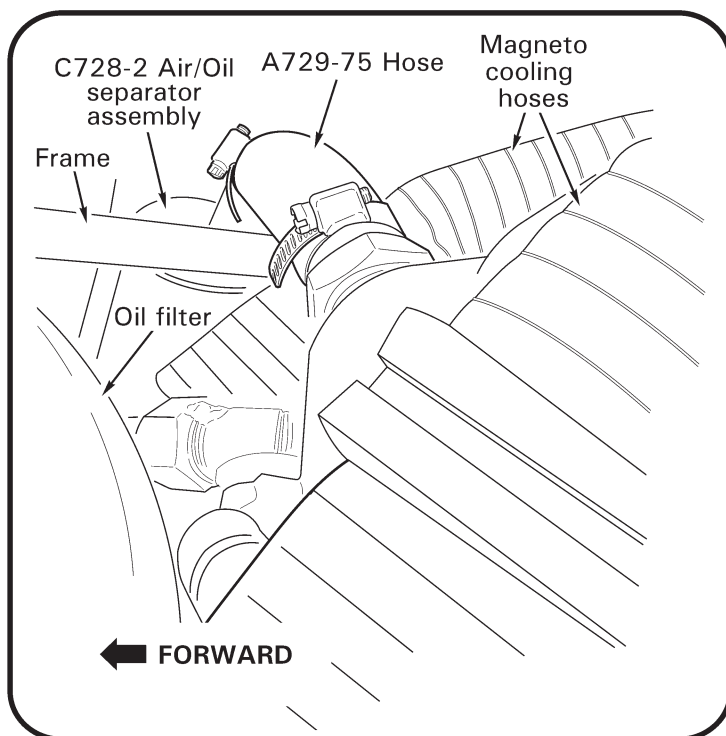

FIGURE 1

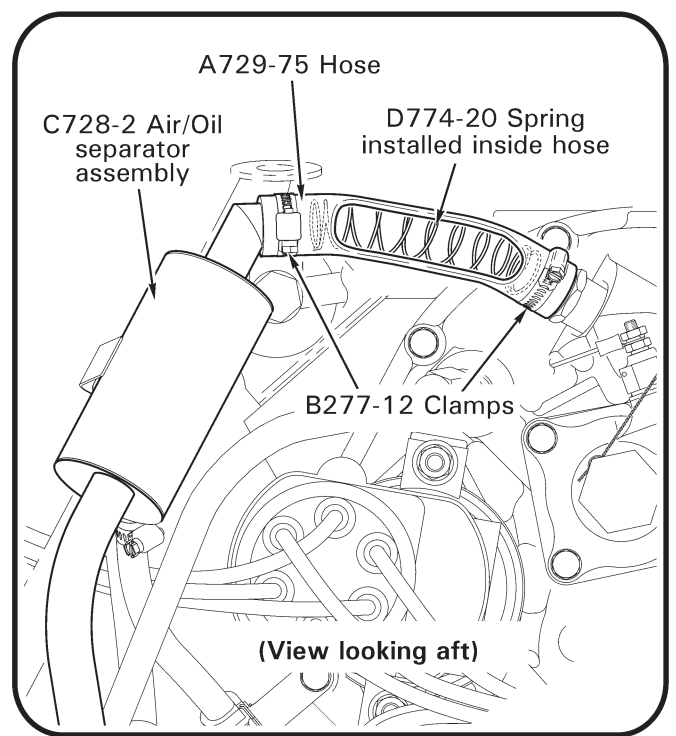

FIGURE 2