

CHAPTER 63**MAIN ROTOR DRIVE SYSTEM**

<u>Section</u>	<u>Title</u>	<u>Page</u>
63-00	Description	63.1
63-10	Engine Shaft Weldment	63.1
63-11	(Engine Driveline) Forward Flex Plate Shimming	63.2
63-12	Clutch Assembly	63.5
63-20	Main Rotor Gearbox Assembly	63.6
63-21	Yoke and Seal Replacement	63.8
63-30	Rotor Brake	63.13
63-31	Pad Replacement	63.14
63-40	Rotor RPM	63.14

Intentionally Blank

CHAPTER 63

MAIN ROTOR DRIVE SYSTEM

63-00 Description

The engine is mounted in a 37° nose-up attitude. A sprag-type overrunning clutch mates directly to the splined engine power take-off (PTO) shaft. The clutch is connected to a shaft with flexible couplings at both ends to transmit power to the main gearbox. A ring and pinion spiral bevel gearset at the main gearbox input reduces speed to tail rotor driveline RPM. A second ring and pinion stage reduces speed from tail rotor driveline RPM to main rotor RPM.

The main gearbox is pressure lubricated. The oil is pumped through an airframe-mounted filter and cooled as required by a thermostatically-controlled oil cooler which receives its airflow from the fanwheel. The main gearbox also drives the flight control hydraulic pump.

63-10 Engine Shaft Weldment**A. Removal**

1. Remove tailcone cowling assembly per § 53-23. Remove engine cowling assembly per § 53-21.
2. Remove filter and cage assemblies per § 71-22.
3. Refer to Figure 63-1. Remove hardware securing F453-1 box assembly to F234-1 firewall.
4. Remove hardware securing forward A947-2 flex plate assembly to F910-1 (main gearbox) yoke and F642 (engine) shaft weldment forward flange, noting hardware removed. Remove flex plate, and temporarily support forward portion of shaft weldment.
5. Remove hardware securing shaft weldment to aft A947-2 flex plate assembly. Remove support, then remove shaft weldment through main gearbox compartment.

B. Installation

1. Refer to Figure 63-1. Position F642 engine shaft weldment in helicopter, and install hardware securing shaft weldment to aft A947-2 plate assembly. Standard torque nuts and palnuts per § 20-32, and torque stripe per Figure 5-1.
2. Shim engine driveline per § 63-11.
3. Install hardware securing F453-1 box assembly to F234-1 firewall.
4. Verify 0.2 inch minimum clearance between shaft weldment and firewall grommet; verify equal gap concentrically between shaft and box assembly hole edges. Adjust F174-1 support weldment rod ends per § 53-31 as required.
5. Install filter and cage assemblies per § 71-22.
6. Install tailcone cowling assembly per § 53-23. Install engine cowling assembly per § 53-21.

63-11 (Engine Driveline) Forward Flex Plate Shimming

NOTE

The engine driveline is shimmed for 0.040 / 0.000 inch compressive preload. Preload is alleviated by upward movement of main gearbox during flight.

1. Refer to Figure 53-2. Verify F174-1 support weldment rod end engagement measures 0.93 inch from tube end to rod end centerline (nominal; both sides). Verify 0.2 inch minimum clearance between F642 (engine) shaft weldment and firewall grommet; verify equal gap concentrically between shaft and F453-1 box assembly hole edges. Adjust support weldment rod end engagement per Section 53-31 as required.
2. Refer to Figure 63-1. If not previously accomplished, remove hardware securing forward A947-2 flex plate assembly to F910-1 (main gearbox) yoke and F642 (engine) shaft weldment forward flange. Remove flex plate, and temporarily support forward portion of shaft weldment.
3. Measure flex plate thickness at bonded washers (4 places) to determine average thickness:

(1st place) _____ inch

(2nd place) + _____ inch

(3rd place) + _____ inch

(4th place) + _____ inch

Total = _____ inch

Total ÷ 4 = _____ inch **(Flex plate average thickness)**

4. a. Position F910-1 (main gearbox) yoke flange arms and F642 (engine) shaft weldment forward flange arms at 3 o'clock and 9 o'clock positions (horizontal). Measure gap between arms to determine average gap:

(3 o'clock position) _____ inch

(9 o'clock position) + _____ inch

Total = _____ inch

Total ÷ 2 = _____ inch **(Average gap between flange arms)**

- b. Rotate F642 (engine) shaft weldment 180°, and repeat step a:

(3 o'clock position) _____ inch

(9 o'clock position) + _____ inch

Total = _____ inch

Total ÷ 2 = _____ inch **(Average gap between flange arms)**

63-11 (Engine Driveline) Forward Flex Plate Shimming (continued)

5. Evaluate flange straightness by calculating the difference between the 3 o'clock positions in steps 4a and 4b. Also calculate the difference between the 9 o'clock positions in steps 4a and 4b. If either calculated difference exceeds 0.015 inch, either one or both flanges are bent and require replacement.
6. Using the smaller average gap from step 4a or 4b, subtract the flex plate average thickness determined in step 3:

Smaller average gap between flange arms (step 4a or 4b) _____ inch

Subtract flex plate average thickness (step 3) – _____ inch

Total = _____ inch

7. Select shims per Table 63-1 and install forward A947-2 flex plate assembly. Standard torque hardware per § 20-32 and torque stripe per Figure 5-1. Remove F642 (engine) shaft weldment temporary support.

WARNING

Shim both arms of flanges equally. All fasteners must meet torque requirements given in § 20-33.

Calculated Dimension	Shim required between forward A947-2 flex plate and F910-1 (main gearbox) yoke	Shim required between forward A947-2 flex plate and F642 (engine) shaft weldment forward flange
–0.041 inch or greater negative number	NAS1149F0432P washer between aft A947-2 flex plate assembly and F642 (engine) shaft weldment aft flange and/or F018-1 clutch assembly yoke may be relocated under nut as required to achieve –0.040 / 0.000 inch calculated dimension. Relocate washers as required, and repeat steps 4 thru 7.	
–0.040 / 0.000 inch	None	None
+0.001 / +0.029 inch	NAS1149F0432P washer	None
+0.030 / +0.059 inch	NAS1149F0432P washer	NAS1149F0432P washer
+0.060 / +0.090 inch	NAS1149F0463P washer	NAS1149F0432P washer
+0.091 / +0.121 inch	NAS1149F0463P washer	NAS1149F0463P washer
+0.122 inch or greater positive number	NAS1149F0432P washer between aft A947-2 flex plate assembly and F642 (engine) shaft weldment aft flange and/or F018-1 clutch assembly yoke may be exchanged with NAS1149F0463P washer as required to achieve –0.040 / 0.000 inch calculated dimension. Exchange washers as required, and repeat steps 4 thru 7.	

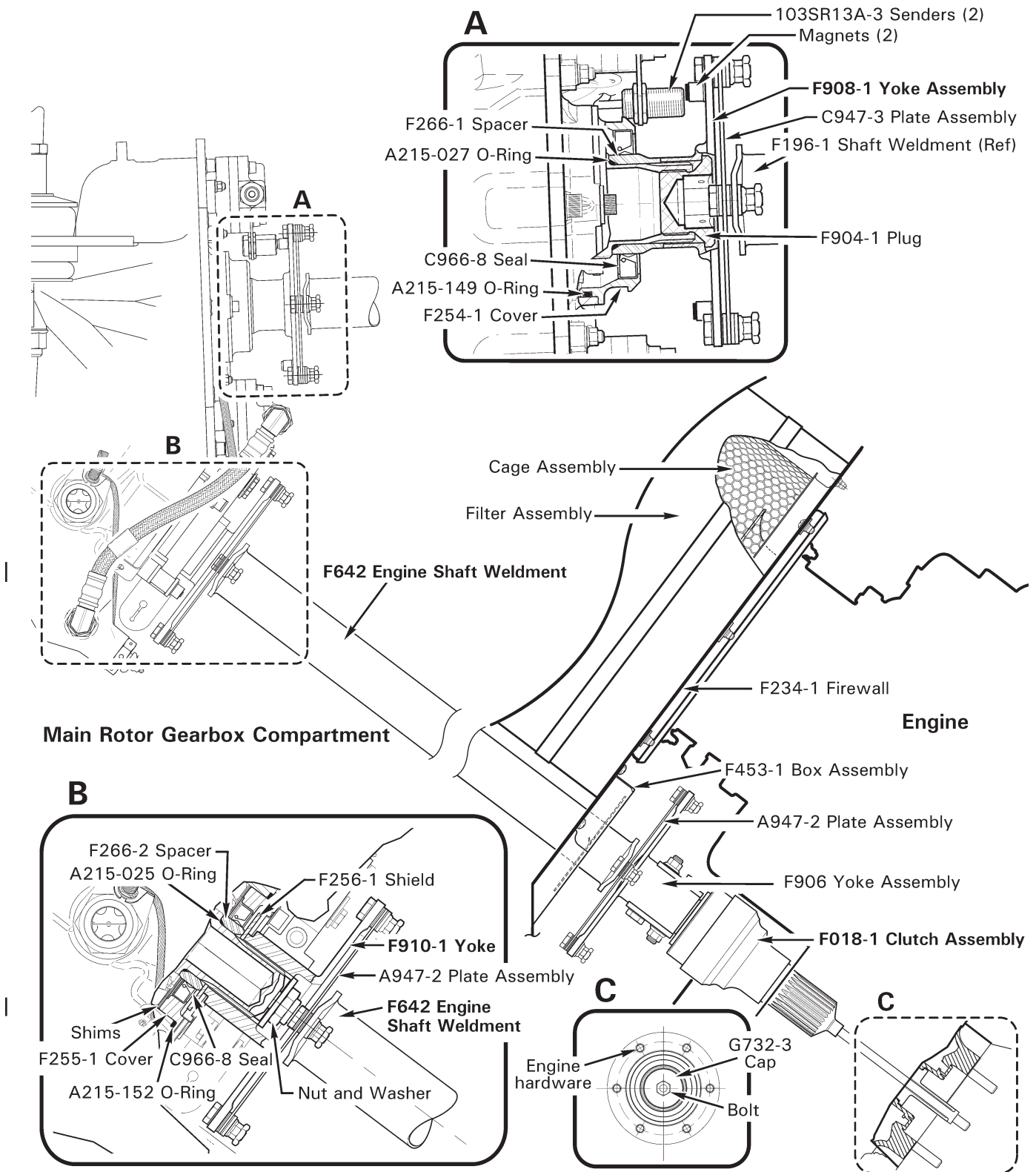

FIGURE 63-1 ENGINE DRIVELINE

63-12 Clutch Assembly**A. Removal**

1. Remove engine shaft weldment per § 63-10.
2. Refer to Figure 63-1. Mark F906 yoke assembly and A947-2 plate assembly, to facilitate installation. Remove plate assembly, noting hardware removed.
3. Remove bolt securing G732 cap, spacer (if installed), and F018-1 clutch assembly to Rolls-Royce engine model 250-C300/A1. Remove clutch assembly through main rotor gearbox compartment.

B. Installation

1. Refer to Figure 63-1. Lubricate F018-1 clutch assembly splines using A257-1, -9, or -12.
2. Route clutch assembly through main rotor gearbox compartment, insert clutch assembly in Rolls-Royce engine model 250-C300/A1, and install spacer (earlier R66s), G732 cap, and bolt at rear PTO pad. Standard torque bolt per § 20-32 and torque stripe per Figure 5-1.
3. Install A947-2 plate assembly, as removed. Standard torque fasteners per § 20-32, and torque stripe per Figure 5-1.
4. Install engine shaft weldment per § 63-10.

63-20 Main Rotor Gearbox Assembly**A. Removal**

1. Remove main rotor blades per § 62-10.
2. Remove tailcone cowling assembly per § 53-23.
3. Disconnect (pitot system) 15-4-N-O union near G201-1 (servo support) frame assembly. Cap fitting and plug line.
4. Refer to Figure 63-1. Remove hardware securing F908-1 and F910-1 yoke assemblies to plate assemblies, leaving plates attached to shaft weldments. Note hardware removed.
5. Remove hardware securing F121-7 push-pull tube assembly to F339-1 jackshaft weldment, and F121-5 push-pull tube assemblies to D212-5 servo assemblies.
6. Detach cable assembly from (rotor brake assembly) B112-3 spring.
7. Using back-up wrench, disconnect D205-19 and D205-20 hose assemblies from F006-1 main rotor gearbox and D500-3 oil pump. Cap and plug fittings and hoses.
8. Disconnect F059-01 cabin harness assembly plug from F049-01 gearbox harness assembly receptacle. Remove hardware securing A936-3 (ground) wire assembly to F560-1 bulkhead assembly.
9. Remove D277-8 clamp or cut and discard safety wire securing Tygon® tube to G254-1 (fuel) vent assembly, and clear tubing from workspace.
10. Install hoisting equipment per § 7-20, Part A, steps 1 thru 4; remove hoist slack.
11. Remove hardware securing F252-1 strut to F020-1 upper frame assembly. Remove (mounting bolt) nuts and washers securing gearbox to upper frame. Remove aft mounting bolts securing F235-13 strut assemblies to servo support frame, hardware securing struts to upper frame, and struts.
12. Hoist gearbox (with hydraulic installation, servo support frame, and mast fairing assembled) up and away from helicopter.

63-20 Main Rotor Gearbox Assembly (continued)**B. Installation****CAUTION**

If F006-1 main gearbox is to be installed in a helicopter equipped with a cargo hook or agricultural sprayer, verify gearbox has B900-12 modification plate adjacent to the gearbox S/N data plate, or has been overhauled (see maintenance records).

1. If installing new C653-3 (aft) or A653-2 (forward) rubber mounts, lubricate mounts using water or A257-8 lubricant and press into gearbox ears.
2. Refer to § 7-20. Hoist F006-1 main rotor gearbox (with hydraulic installation, G201-1 [servo support] frame assembly, and mast fairing assembled) into helicopter, onto F020-1 upper frame assembly.
3. Install F252-1 strut and F235-13 strut assemblies, and install hardware securing strut assemblies to upper frame. Install gearbox mounting bolts and associated hardware, and apply light coat A257-9 anti-seize to threads. Special torque mounting bolts per § 20-33, standard torque bolts securing struts to upper frame per § 20-32, and torque stripe per Figure 5-1.
4. Remove hoisting equipment, and lifting fixture or nylon rope.
5. Install Tygon® tube on G254-1 (fuel) vent assembly and install D277-8 clamp. Verify security.
6. Install hardware securing A936-3 (ground) wire assembly to F560-1 bulkhead assembly. Connect F059-01 cabin harness assembly plug to F049-01 gearbox harness assembly receptacle.
7. Remove caps and plugs and connect D205-19 and D205-20 hose assemblies to gearbox and D500-3 oil pump. Using back-up wrench, special torque hose nuts per § 20-33, and torque stripe per Figure 5-1.
8. Attach (rotor brake) D126-2 cable assembly to (rotor brake assembly) B112-3 spring. Verify 0.25 inch minimum clearance between cable assembly and vent assembly Tygon® tube; adjust cable attachments as required.
9. Install hardware securing F121-7 push-pull tube assembly to F339-1 jackshaft weldment, and F121-5 push-pull tube assemblies to D212-5 servo assemblies. Standard torque hardware per § 20-32 and torque stripe per Figure 5-1.
10. Install hardware securing F908-1 and F910-1 yoke assemblies to plate assemblies, as removed. Shim engine driveline per § 63-11, and tail rotor driveline per § 65-30. Standard torque hardware per § 20-32, and torque stripe per Figure 5-1.
11. Install tailcone cowling assembly per § 53-23.

63-20 Main Rotor Gearbox Assembly (continued)**B. Installation (continued)**

12. Install main rotor blades per § 62-10.

CAUTION

Prior to operation of a new, overhauled, or repaired main rotor gearbox, inject 5–6 ounces A257-22 oil into mast tube vent hole (not required if main gearbox has C251-3 Rev Q or subsequent main drive shaft installed). Service gearbox per § 12-11.

63-21 Yoke and Seal Replacement**A. (Tail Rotor Drive) F908-1 Yoke Assembly and Seal Removal**

1. Remove tailcone cowling assembly per § 53-23.
2. Remove hardware securing aft F305-5 inlet to scroll assembly; rest inlet on F196-1 fan shaft.
3. Refer to Figure 63-1. Remove forward C947-3 flex plate assembly, noting hardware removed. Remove intermediate C947-3 flex plate assembly, noting hardware removed. Carefully maneuver fan shaft aft to access main gearbox's F908-1 yoke.
4. Refer to Figure 63-2. Set rotor brake. Remove and discard lockwire securing F904-1 plug to yoke and remove plug using a 3/4-inch hex-bit socket. Visually inspect forward C947-3 flex plate assembly and plug for damage. Order replacement parts from [RHC Customer Service](#) if damage is found.
5. Remove hardware securing F254-1 cover with C966-8 seal to F006-1 main rotor gearbox. Remove cover.
6. Using hydraulic press, press old seal from cover.

B. (Tail Rotor Drive) F908-1 Yoke Assembly and Seal Installation

1. Refer to Figure 63-1. Remove F266-1 spacer and replace A215-027 o-ring, as required. Reinstall spacer.
2. Clean and dry F254-1 cover; verify open face of seal points toward gearbox and press in new seal until completely seated.
3. Replace A215-149 o-ring, as required. Install cover assembly over pinion shaft.
4. Verify yoke and pinion splines are clean and undamaged. Coat splines of pinion with B270-21 protectant and install F908-1 yoke assembly.
5. Refer to Figure 63-2. Apply light coat of A257-9 anti-seize to F904-1 plug threads, install plug in gearbox, and special torque plug per MM § 20-33.

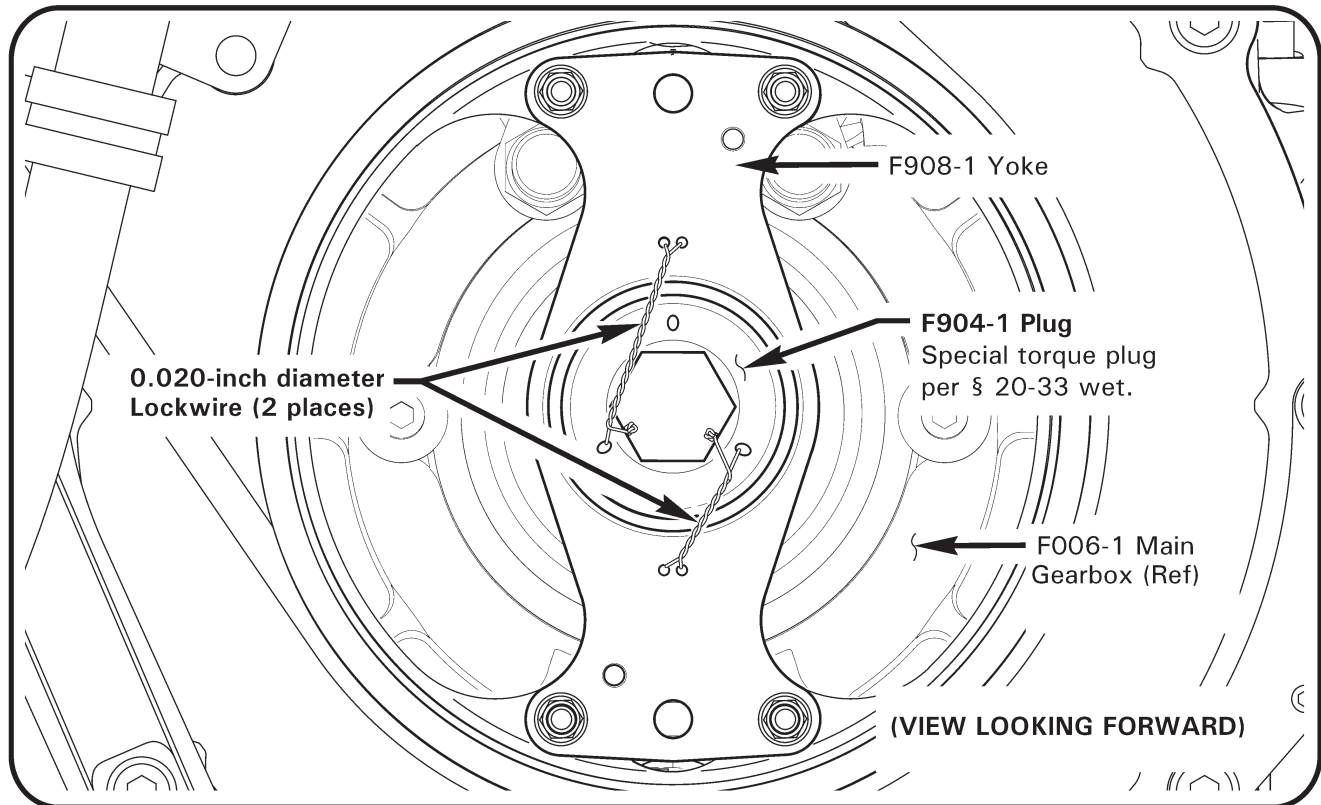

FIGURE 63-2 F908-1 YOKE ASSEMBLY INSTALLATION

63-21 Yoke and Seal Replacement (continued)

B. (Tail Rotor Drive) F908-1 Yoke Assembly and Seal Installation (continued)

6. In two places, install 0.020-inch diameter lockwire and safety plug to yoke with pigtails inside recess of plug as shown.
7. Install forward C947-3 flex plate assembly, using hardware removed (replace palnuts). Standard torque hardware per MM § 20-32 and torque stripe per MM Figure 5-1. Ensure safety wire is not contacting flex plate.
8. Install and shim intermediate C947-3 flex plate assembly per MM § 65-30.
9. Install hardware securing aft F305-5 inlet to scroll assembly. Verify 0.10 inch minimum gap between fanwheel assembly and inlet.
10. Install tailcone cowling assembly per § 53-23.
11. Set hall effect sender-to-magnet gap per § 63-40.

63-21 Yoke and Seal Replacement (continued)**C. (Engine-Driven) F910-1 Yoke Assembly and Seal Removal**

1. Remove tailcone cowling assembly per § 53-23. Remove engine cowling assembly per § 53-21.
2. Drain main gearbox oil per § 12-11.
3. Refer to Figure 63-1. Remove hardware securing A947-2 (forward) plate assembly to F910-1 yoke assembly, and A947-2 (aft) plate assembly to F642 shaft weldment, noting hardware removed. Support weldment to allow clearance for yoke removal.
4. Place a wood block between firewall and yoke flange (to prevent yoke from rotating) or engage rotor brake. Remove nut and washer securing yoke to pinion, then remove yoke.
5. Remove rotor brake per § 63-30.
6. Remove F255-1 cover with C966-8 seal, but do not remove shims under pinion bearing. Remove F266-2 spacer.
7. Using hydraulic press, press old seal from cover.

D. (Engine-Driven) F910-1 Yoke Assembly and Seal Installation**CAUTION**

Do not remove shims under pinion bearing. Shims control bearing preload and gear backlash.

1. Refer to Figure 63-1. Replace A215-025 o-ring, as required.
2. Clean and dry F255-1 cover; verify open face of seal points toward gearbox and press in new seal until completely seated.
3. Replace A215-152 o-ring, as required. Install cover assembly over pinion shaft. Install F266-2 spacer.
4. Install rotor brake per § 63-30.
5. Service main gearbox per § 12-11.

Intentionally Blank

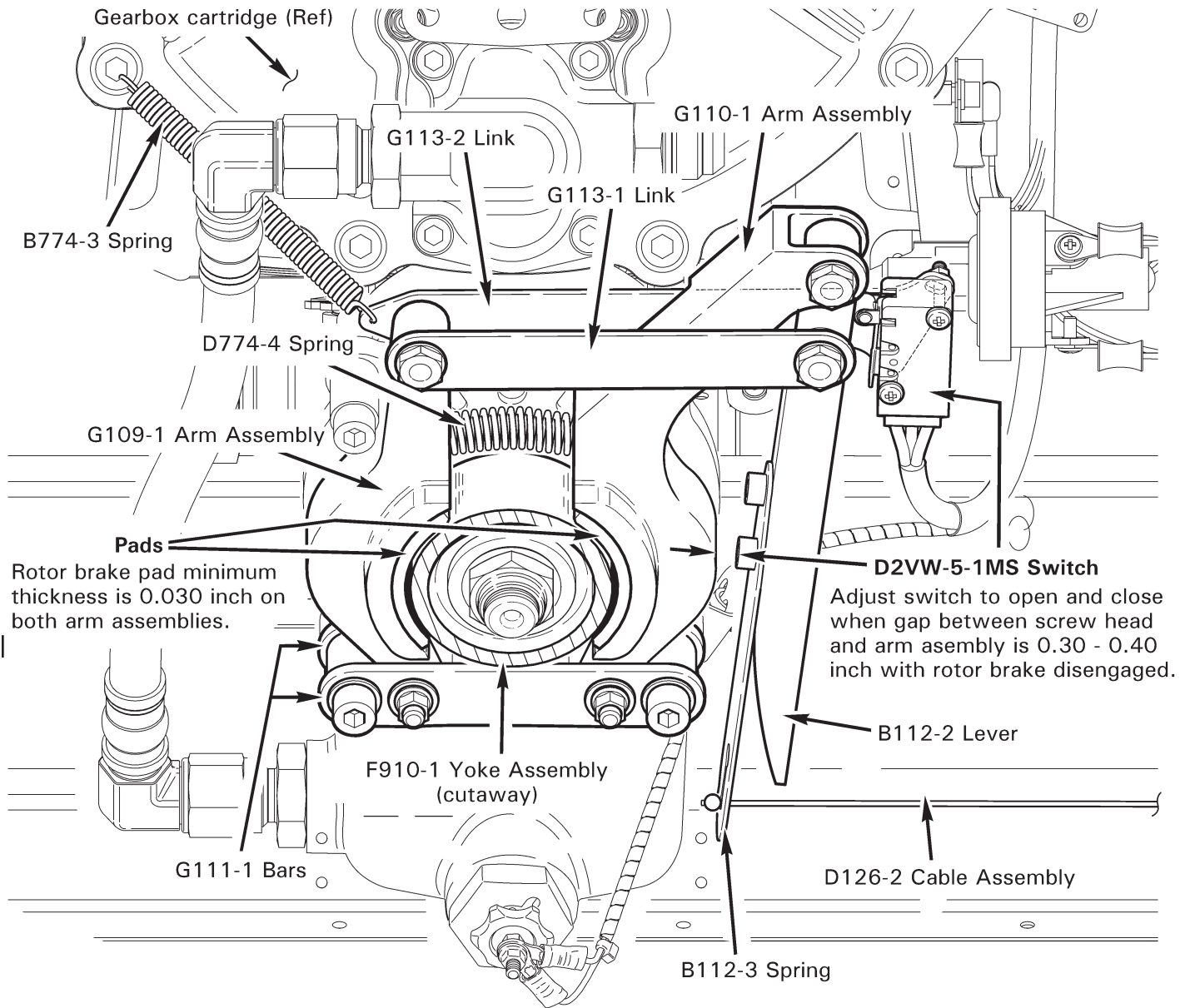

FIGURE 63-3 ROTOR BRAKE

63-30 Rotor Brake**A. Removal**

1. Remove (engine-driven) F910-1 yoke assembly per § 63-21, Part C steps 1 thru 3.
2. Refer to Figure 63-3. Detach D126-2 cable assembly from B112-3 spring. Detach B774-3 spring from gearbox cartridge retaining screw or rotor brake assembly link.
3. Remove hardware securing D2VW-5-1MS switch to brake assembly link.
4. Remove hardware and spacers securing brake assembly mounting bars to gearbox cartridge. Remove G033-1 brake assembly F256-1 shield (see Figure 63-1).

B. Installation

1. Refer to Figure 63-3. Verify minimum 0.030 inch rotor brake pad thickness on both arm assemblies.
2. Verify F910-1 yoke assembly and pinion splines are clean and undamaged. Coat splines of pinion with B270-21 protectant.
3. Install F256-1 shield, then position G033-1 brake assembly over pinion and install spacers and hardware securing brake assembly mounting bars to gearbox cartridge. Standard torque screws per § 20-32 and torque stripe per Figure 5-1.
4. Install yoke on pinion shaft. Place a wood block between firewall and yoke flange (to prevent yoke from rotating). Install pinion retaining nut and washer and special torque nut per § 20-33. Coat nut and exposed pinion splines with B270-21 protectant. When dry, torque stripe per Figure 5-1.
5. Attach B774-3 spring to gearbox cartridge retaining screw and rotor brake assembly link. Attach D126-2 cable assembly to B112-3 spring.
6. Install hardware securing D2VW-5-1MS switch to brake assembly link, but do not tighten. Adjust switch to open and close when gap between B112-3 spring lower retaining screw screw head and G110-1 arm assembly is 0.30–0.40 inch with brake disengaged. Pivot switch about lower fastener as required and tighten fasteners to set gap. Function check rotor brake light.
7. Install hardware securing A947-2 (forward) plate assembly to F910-1 yoke assembly, and A947-2 (aft) plate assembly to F642 shaft weldment. Shim engine driveline per § 63-11. Standard torque hardware per § 20-32, and torque stripe per Figure 5-1.
8. Install tailcone cowling assembly per § 53-23. Install engine cowling assembly per § 53-21.

63-31 Pad Replacement**A. Arm Removal****NOTE**

Rotor brake pad minimum thickness is 0.030 inch on both arm assemblies. Replace arm assemblies when pads are worn beyond limit.

1. Remove rotor brake per § 63-30.
2. Remove hardware and spacers securing G109-1 arm assembly to (2) G111-1 bars and G113-1 & -2 links. Remove D774-4 spring.
3. Remove hardware and spacers securing G110-1 arm assembly to (2) G111-1 bars and B112-2 lever. Loosen fastener securing G113-1 & -2 links to B112-2 lever.

B. Arm Installation

1. Refer to Figure 63-3. Lubricate spacers with A257-1 grease and install in new G110-1 arm assembly. Install hardware securing G110-1 arm assembly to (2) G111-1 bars and B112-2 lever, but do not torque.
2. Lubricate spacers with A257-1 grease and install in new G109-1 arm assembly. Install D774-4 spring, and install hardware securing G109-1 arm assembly to (2) G111-1 bars and G113-1 & -2 links. Standard torque all bolts and torque stripe per Figure 5-1.
3. Install rotor brake per § 63-30.

63-40 Rotor RPM

1. Remove tailcone cowling assembly per § 53-23.
2. Refer to Figure 63-1. Measure gap between both F908-1 yoke assembly magnets at each 103SR13A-3 (Hall effect) sender. Verify gap is between 0.030 ± 0.010 inch.
3. As required, loosen sender jam nuts and adjust to obtain 0.030 ± 0.010 inch gap. Special torque jam nuts per § 20-33 and torque stripe per Figure 5-1.
4. Install tailcone cowling assembly per § 53-23.