

R22 SERVICE LETTER SL-74A

(supersedes R22 SL-74)

R44 SERVICE LETTER SL-61A

(supersedes R44 SL-61)

DATE: 21 July 2017

REV A: 20 December 2017

TO: R22-series & R44-series Owners, Operators, and Maintenance Personnel

SUBJECT: A185 Brackets Installation & Fiberglass Scroll Repair

BACKGROUND: Perform whenever looseness of an A185 bracket is detected or suspected, and whenever upper or lower scroll is removed. Refer to R22 SB-112 & R44 SB-94.

COMPLIANCE PROCEDURE:

1. If any A185 bracket is suspected to be loose, remove scroll per Maintenance Manual (MM) Chapter 6.
2. Inspect security of A185 brackets on scroll.
 - a. If none of three A185 brackets are loose on scroll:
 - i. Refer to Figure 1. Count rivets attaching three A185 brackets to scroll. If less than 3 rivets at any location (4 places), install center rivets between existing rivets as shown and replace existing 1/8-inch diameter rivets with 5/32-inch diameter rivets. Proceed to step 16.
 - b. If only one of three A185 brackets is loose on scroll:
 - i. Mark orientation of associated A185-3 plate. Remove loose bracket and plate by drilling out attaching rivets.
 - ii. Verify rivet holes in scroll, bracket, and plate do not exceed 0.164 inch diameter. Enlarge rivet holes in bracket and associated plate by match drilling to 0.164 inch diameter.
 - iii. Refer to Figure 1. Assemble upper & lower scroll halves with screws. Position an A181/C181 bearing housing on scroll between three A185 brackets and secure housing to brackets with AN3-41A bolts and washers. Verify rivet holes in unriveted A185 bracket align with rivet holes in scroll. If hole alignment is satisfactory, attach loose A185 bracket & associated plate to scroll with three solid rivets per Figure 1 and proceed to step 15.
 - iv. Remove AN3-41A bolts and bearing housing and disassemble scroll halves.

(OVER)

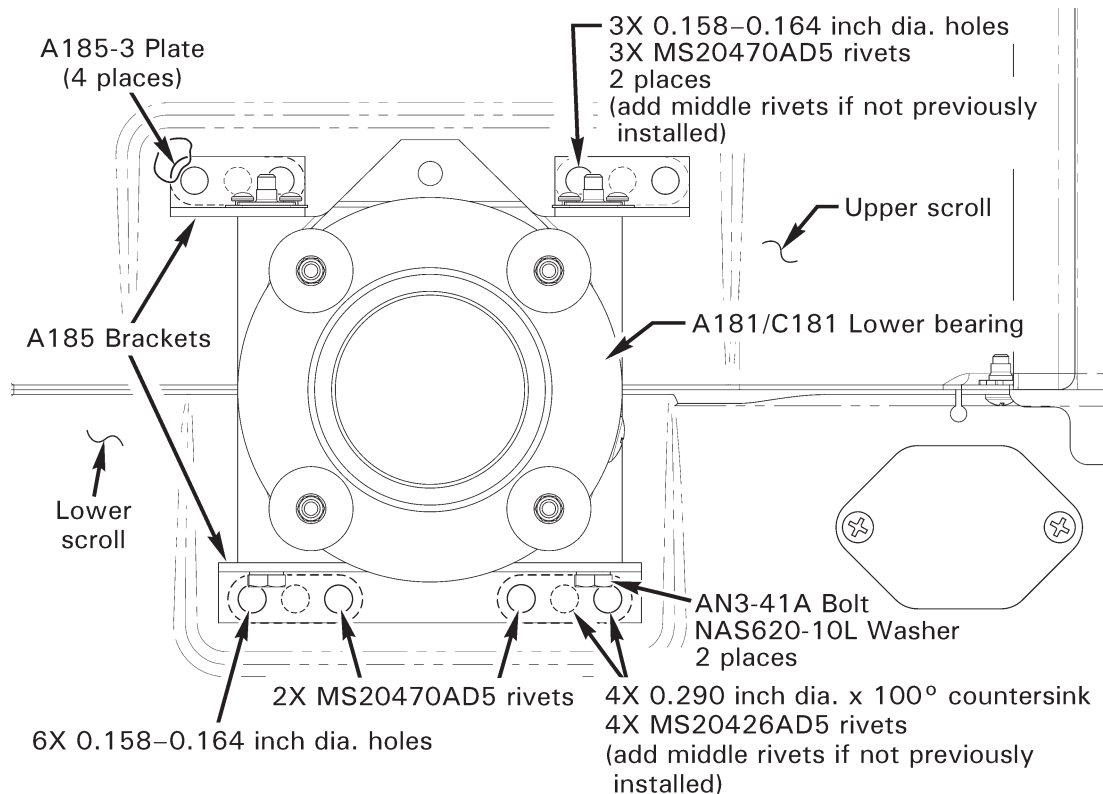

FIGURE 1

CAUTION

Use proper personal protective equipment when handling fiberglass.

2. b. v. Repair (fill) oversize and/or misaligned rivet holes in scroll per U.S. FAA AC 43.13-1B para 3-3.a (online at www.faa.gov). Scroll material is Style 7533, plain weave, 18x18 threads/inch, 5.8 ounce/sq.yard, fiberglass cloth with polyester resin; for repair purposes, epoxy resin is recommended instead of polyester resin.
- c. If two or three A185 brackets are loose on scroll:
 - i. Mark locations and orientation of associated A185-3 plates. Remove all brackets and inner plates by drilling out attaching rivets.
 - ii. Fill all rivet holes per step 2.b.v.
3. Clean upper scroll. Apply a light coating of layout dye (or contrasting lacquer paint) in area where A181/C181 bearing resides.
4. Remove lower sheave per MM § 7.290.

5. Rotate crankshaft using starter ring-gear support until largest diameter bushing in crankshaft flange (typically stamped "0" adjacent) is at 12 o'clock position and bushing bore is visually aligned with crankcase split line.
6. Without moving crankshaft, loosen alternator belt and remove starter ring gear support.
7. Install (3) NAS1149F1290P (AN960-1216) washers on each crankshaft flange bushing at 2-, 6-, & 10-o'clock positions (washers substitute for thickness of removed starter ring gear support).
8. Without moving crankshaft, install lower sheave and fan shaft & bearing assy on crankshaft using bolts at 2-, 6-, & 10-o'clock positions. Hand tighten bolts.
9. Refer to Figure 2. Visually align actuator mounting holes in A181/C181 bearing housing with upper empty bolt hole in crankshaft. Insert a sufficiently long & straight 0.250-inch diameter drill (or straight, pointed-screwdriver shank) thru holes in bearing housing until drill point contacts crankcase, then rotate bearing housing as required until drill point aligns with crankcase split line. Prevent bearing housing rotation with duct tape. Cut-off portion of drill shank which protrudes beyond bearing housing.
10. Position upper scroll on engine and secure corners to cooling panels with at least 6 screws & nuts.
11. Using suitable scribe, trace outline of A181/C181 bearing housing into layout dye on upper scroll. Verify drill point in bearing housing remains aligned with crankcase split line.
12. Remove drill, duct tape, upper scroll half, fanshaft & bearing assembly, lower sheave, and washers.
13. Refer to Figure 1. Assemble upper & lower scroll halves with screws. Assemble and secure (3) A185 brackets to A181/C181 bearing housing with AN3-41A bolts and washers. Align bearing housing and attached brackets with scribed lines on upper scroll.
14. Using A185 brackets as a guide, progressively drill twelve 0.158/0.164 inch diameter holes thru brackets, scroll, and plates, and install solid rivets per Figure 1.
15. Remove AN3-41A bolts, disassemble scroll halves, and clean up debris. Remove layout dye and paint scroll as required.
16. Install alternator belt (a new alternator belt is recommended), starter ring gear support, lower sheave and fanshaft & bearing assembly per MM § 7.290.
17. On lower A185 bracket, apply torque seal in a vertical stripe across both outboard rivets to lower scroll to facilitate future inspections.
18. Make appropriate maintenance record entries.

(OVER)

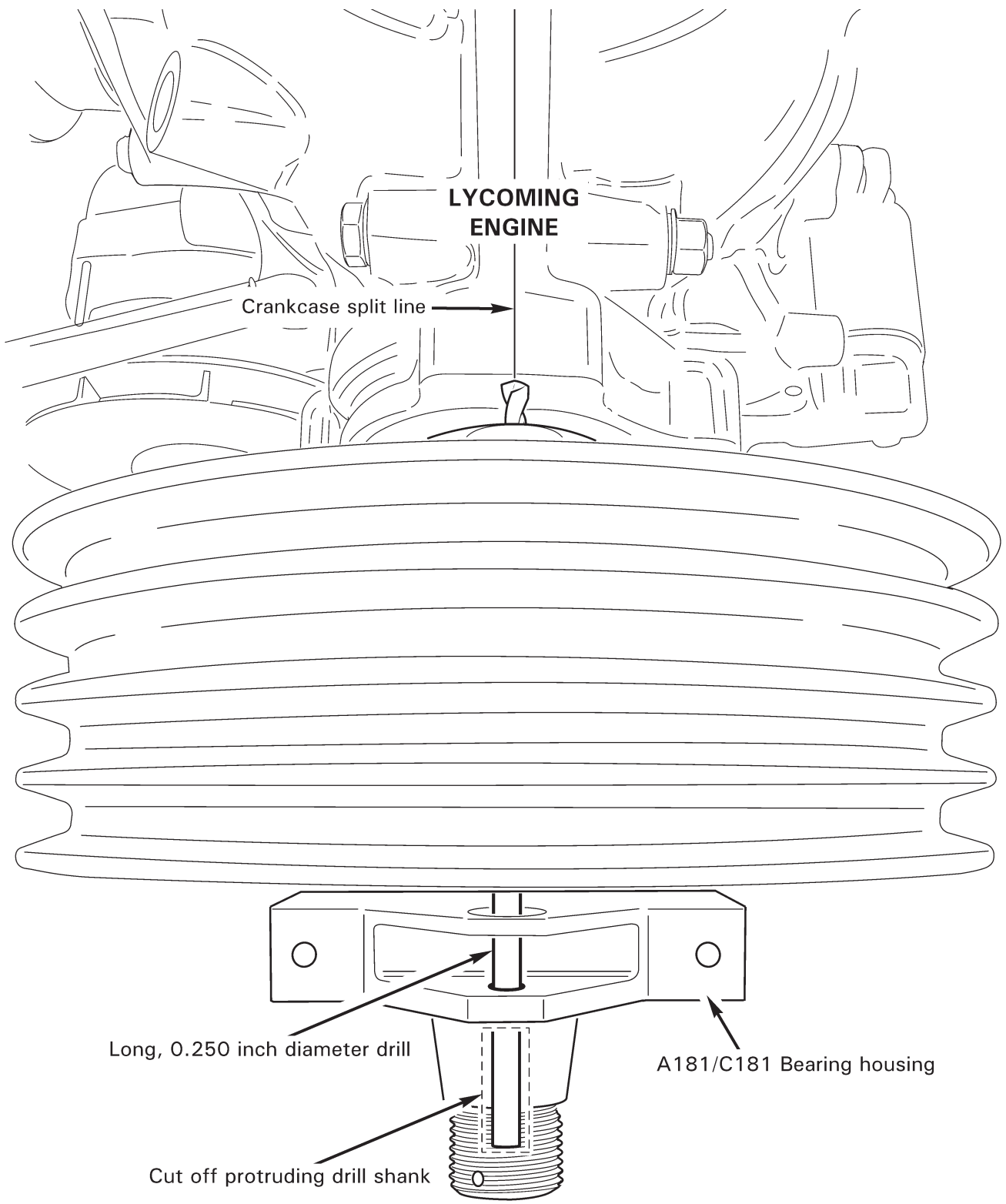

VIEW LOOKING DOWN
(R22 shown, R44 is similar)

FIGURE 2