

R66 TURBINE & TURBINE MARINE



The five-seat R66 Turbine helicopter is reliable, economical and easy to maintain. R66s have a two-bladed rotor system, a T-bar cyclic and hydraulic power controls that eliminate feedback forces.

The R66's spacious 300 lb capacity baggage compartment along with the powerful Rolls Royce RR300 turbine engine give operators greater utility. The lightweight RR300 engine operates on readily available Jet A fuel, delivering increased reserve power, additional payload and improved altitude performance.

The R66 meets the FAA's current crash-worthiness regulations and features the latest in Robinson technology including streamlined instrument panels, energy absorbing seats and crashworthy bladder fuel tanks.

OPTIONS

- Air Conditioning
- 43-Gallon Auxiliary Fuel Tank
- Leather Seats in Tan, Charcoal or Gray
- Garmin and Aspen Primary and Multifunction Flight Displays
- Garmin GTN 600/700 Series Touchscreen Navigators
- Genesys HeliSAS Autopilot
- Garmin ADS-B Compliant Transponders
- Garmin GMA 350Hc Audio Panel
- Bose A20 Headsets with Bluetooth



Panel shown with optional Garmin G500H, Garmin GTN 750, Genesys HeliSAS Autopilot, GMA 350H audio controller, right accessory bar and fire extinguisher



Standard Panel shown with optional artificial horizon, directional gyro, turn coordinator and fire extinguisher

R66 TURBINE & TURBINE MARINE

SPECIFICATIONS

Helicopter	R66 Turbine	R66 Turbine Marine with pop-out floats
Engine	Rolls Royce RR300 turbine	Rolls Royce RR300 turbine
Horsepower	300 shp turboshaft; derated to 270 shp for takeoff and 224 shp continuous	300 shp turboshaft; derated to 270 shp for takeoff and 224 shp continuous
Maximum Gross Weight	2700 lb (1225 kg)	2700 lb (1225 kg)
Approximate Empty Weight (including oil & std avionics)	1280 lb (581 kg)	1345 lb (610 kg)
Fuel Capacity (73.6 gal)	493 lb (224 kg)	493 lb (224 kg)
Pilot, Passengers, and Baggage (with maximum fuel)	927 lb (420 kg)	862 lb (391 kg)
Cruise Speed at Maximum Gross Weight	up to 110 kts (204 km/h)	up to 110 kts (204 km/h)
Maximum Range (no reserve)	approx 350 nm (650 km)	approx 350 nm (650 km)
Hover Ceiling IGE at Maximum Gross Weight	over 10,000 ft	over 10,000 ft
Hover Ceiling OGE at Maximum Gross Weight	over 10,000 ft	over 10,000 ft
Rate of Climb	over 1000 fpm	over 1000 fpm
Maximum Operating Altitude	14,000 ft	14,000 ft
Electrical System	28 volt	28 volt

DIMENSIONS

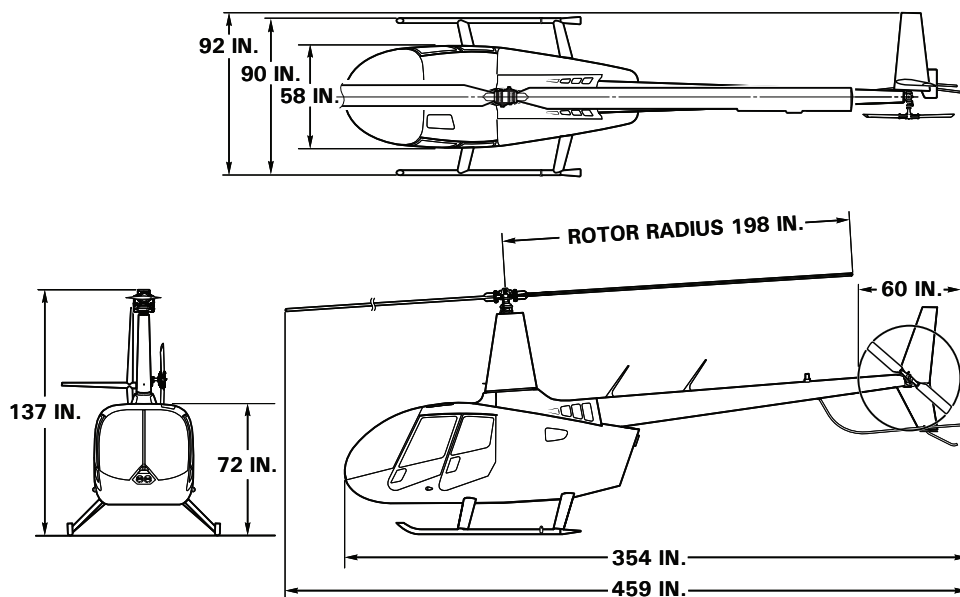

STANDARD AVIONICS

- Eight-hole instrument panel
- GTR 225B COM radio
- GMA 350Hc audio panel
- GTX 327 Mode C transponder

STANDARD INSTRUMENTS

- Airspeed indicator
- Altimeter
- Rotor/engine dual tachometer
- Vertical speed indicator
- Magnetic compass
- Torque meter
- N1 tachometer
- MGT gage
- Oil temp and pressure gages
- Fuel gage
- Ammeter
- Digital OAT gage/voltmeter
- Hourmeters
- Quartz clock

STANDARD EQUIPMENT

- Hydraulic power controls
- Bladder fuel tank
- Integrated oil filter with bypass indicator
- Engine air filter with bypass indicator
- Main gearbox oil filter
- 160 amp starter generator
- Engine compressor rinse nozzle
- Electronic engine monitoring unit (EMU)
- Engine anti-ice system
- Cabin heater and defogger
- Rotor brake
- Intercom switches
- Avionics master switch
- Tinted windows
- Leather seats
- 3-point shoulder harnesses
- Pilot-side adjustable pedals
- Door locks
- Belly hardpoint
- LED anti-collision and navigation lights
- Dual HID landing lights
- LED panel and map lights
- Tow cart adapter
- Ground handling wheels
- Rotor blade tie-downs
- Windshield cover
- Travel bag

ROBINSON HELICOPTER COMPANY

2901 Airport Drive • Torrance, CA • 90505 • USA
 Phone: 310-539-0508 • Fax: 310-539-5198
www.robinsonheli.com