

**SECTION 7**

**SYSTEMS DESCRIPTION**

**CONTENTS**

	<b>Page</b>
General . . . . .	7-1
Rotor Systems . . . . .	7-2
Drive System . . . . .	7-2
Powerplant . . . . .	7-3
Flight Controls . . . . .	7-4
Removable Flight Controls . . . . .	7-5
RPM Governor . . . . .	7-6
Hydraulic System . . . . .	7-7
Control Friction Adjustment . . . . .	7-8
Engine Controls . . . . .	7-8
Clutch Actuator . . . . .	7-9
Fuel System . . . . .	7-10
Electrical System . . . . .	7-11
Lighting System . . . . .	7-14
External Power Receptacle (Optional) . . . . .	7-15
Instrument Panel . . . . .	7-15
Audio System . . . . .	7-18
Optional Avionics . . . . .	7-18
Pitot-Static System . . . . .	7-19
Dual Tachometer . . . . .	7-19
Warning and Caution Lights . . . . .	7-20
Cabin Heating and Ventilation . . . . .	7-21
Seats, Belts, and Baggage . . . . .	7-21
Landing Gear . . . . .	7-22
Rotor Brake . . . . .	7-23
Engine Primer System (Optional) . . . . .	7-23
Carbon Monoxide Detector . . . . .	7-24
Emergency Locator Transmitter (Optional) . . . . .	7-25
Optional Accessory Mounts . . . . .	7-26

INTENTIONALLY BLANK

## **SECTION 7**

### **SYSTEMS DESCRIPTION**

#### **GENERAL**

The R44 Cadet is a two-place, single main rotor, single engine helicopter constructed primarily of metal and equipped with skid-type landing gear.

The primary fuselage structure is welded steel tubing and riveted aluminum sheet. The tailcone is a monocoque structure in which aluminum skins carry most primary loads. Fiberglass and thermoplastics are used in secondary cabin structure, engine cooling shrouds, and various other ducts and fairings. The cabin doors are also constructed of fiberglass and thermoplastics.

Four right-side cowl doors provide access to the main gearbox, drive system, and engine. A left-side engine cowl door provides access to the engine oil filler and dip stick. Additional access to controls and other components for maintenance is provided by removable panels and cowlings.

Stainless steel firewalls are located forward of and above the engine.

The four cabin doors are removable. Refer to Section 8 for removal and installation procedures.

## **ROTOR SYSTEMS**

The main rotor has two all-metal blades mounted to the hub by coning hinges. The hub is mounted to the shaft by a teeter hinge. The coning and teeter hinges use self-lubricated bearings. Droop stops for the main rotor blades provide a teeter hinge friction restraint which normally prevents the rotor from teetering while starting or stopping. Pitch change bearings for each blade are enclosed in a housing at the blade root. The housing is filled with oil and sealed with an elastomeric boot. Each blade has a thick stainless steel spar at the leading edge which is resistant to corrosion and erosion. The skins are bonded to the spar approximately one inch aft of the leading edge. Blades must be refinished before the paint erodes to bare metal at the skin-to-spar bond line. Bond may be damaged if bond line is exposed.

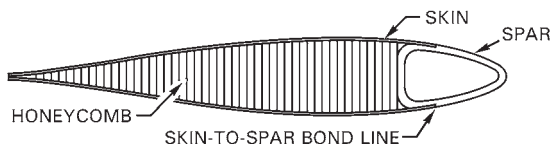

**MAIN ROTOR BLADE CONSTRUCTION**

The tail rotor has two all-metal blades and a teetering hub with a fixed coning angle. The pitch change bearings have self-lubricated liners. The teeter hinge bearings are elastomeric. The tail rotor blades are constructed with aluminum skins and root fittings. Maintaining the paint finish will reduce corrosion and erosion.

## **DRIVE SYSTEM**

A vee-belt sheave is bolted directly to the engine output shaft. Vee-belts transmit power to the upper sheave which has an overrunning clutch contained in its hub. The inner shaft of the clutch transmits power forward to the main rotor and aft to the tail rotor. Flexible couplings are located at the main gearbox input and at each end of the long tail rotor drive shaft.

The main gearbox contains a single-stage spiral-bevel gear set which is splash lubricated. Cooling ducts under the gearbox are connected to the top of the engine cooling scroll. The main gearbox is supported by four rubber mounts.

### **DRIVE SYSTEM (cont'd)**

The long tail rotor drive shaft has no support bearings but has a lightly-loaded damper bearing. The tail gearbox contains a single 90° splash-lubricated spiral-bevel gear set.

### **POWERPLANT**

One Lycoming O-540 six-cylinder, horizontally-opposed, overhead-valve, air-cooled, carbureted engine with a wet sump oil system powers the helicopter. The engine is equipped with a starter, alternator, shielded ignition, two magnetos, muffler, oil cooler, and induction air filter. See Sections 1 and 2 for powerplant specifications and limitations.

A direct-drive, squirrel-cage fan wheel mounted to the engine output shaft supplies cooling air to the cylinders and oil cooler via a fiberglass and aluminum shroud.

Induction air enters through an opening on the right side of the fuselage and passes through a flexible duct to the carburetor air box. A second flexible duct passes heated air from an exhaust-mounted scoop to the air box. A sliding valve controlled by the carburetor heat control adjusts the mix of cool and heated air, which then flows through the air filter and up into the carburetor.

The pilot should adhere to recommended procedures in the Lycoming Operator's Manual to obtain maximum engine life and efficiency.

## **FLIGHT CONTROLS**

Dual controls are standard equipment and all primary controls are actuated through push-pull tubes and bellcranks. Bearings used throughout the control system are either sealed ball bearings which do not require lubrication or have self-lubricated liners.

Flight control operation is conventional. The cyclic is center mounted with the left and right control grips mounted to a cross tube which pivots on the center cyclic post. The pilot's cyclic grip angle can be adjusted fore and aft relative to the cross tube by a mechanic to achieve the most comfortable hand position. The most forward position provides the most control clearance at aft cyclic for larger pilots. Pilots should always verify the ability to apply full control travel prior to flight.

Collective operation is conventional. The engine throttle is correlated to collective inputs through a mechanical linkage. When the collective is raised, the throttle is opened and when the collective is lowered, the throttle is closed. The collective stick also incorporates a twist grip throttle control which is described in the Engine Controls section.

### ***CAUTION***

Above 4000 feet, throttle-collective correlation and governor are less effective. Therefore, power changes should be slow and smooth.

### ***CAUTION***

At high power settings above 6000 feet, the throttle is frequently wide open and RPM must be controlled with collective.

Right-side tail rotor pedals are adjustable. To adjust, remove quick-release pin on each pedal by depressing button and pulling. Slide pedal fore or aft to most comfortable of three adjustment positions and reinstall quick-release pin. Verify pins are secure before flight.

## **REMOVABLE FLIGHT CONTROLS**

Left seat pilot controls may be removed and installed by maintenance personnel or pilots as follows:

1. To remove cyclic grip, remove quick-release pin by depressing button and pulling, then pull outward on left grip while supporting cyclic center post. Rotate right-side cyclic cross tube clockwise to stop, depress stop pin under cyclic pivot, and continue clockwise rotation one turn to wind up balance spring. To install removable cyclic grip, use reverse procedure. A knurled ring next to the quick-release pin may be hand tightened to eliminate freeplay. The ring must be loose (rotate counterclockwise looking inboard) to remove pin.

### ***CAUTION***

Overrotating cyclic cross tube in either wound or unwound direction will damage balance spring.

### ***CAUTION***

After removing cyclic grip, place plastic cap on exposed cyclic cross tube to prevent possible injury to left seat passenger.

2. To remove collective, push boot aft to expose locking pins. Depress locking pins and pull forward on stick. To install, use reverse procedure. It may be necessary to rotate stick slightly to allow pins to snap into place.

### ***CAUTION***

When collective is installed, ensure that both locking pins are fully engaged through holes on each side.

3. To remove tail rotor pedals, depress locking pin while twisting pedal counterclockwise, then pull up. To install, use reverse procedure. A cover which is stowed under the floor scuff plate may be rotated up to cover the floor openings when the pedals are removed.

## **RPM GOVERNOR**

The governor maintains engine RPM by sensing changes and applying corrective throttle inputs through a friction clutch which can be easily overridden by the pilot. The governor is active only above 80% engine RPM and can be switched on or off using the toggle switch on the end of the right seat collective.

The governor is designed to assist in controlling RPM under normal conditions. It may not prevent over- or under-speed conditions generated by aggressive flight maneuvers.

### ***CAUTION***

When operating at high density altitudes, governor response rate may be too slow to prevent overspeed during gusts, pull-ups, or when lowering collective.



## **HYDRAULIC SYSTEM**

Hydraulically-boosted main rotor flight controls eliminate cyclic and collective feedback forces. The hydraulic system consists of a pump, three servos, a reservoir, and interconnecting lines. The working fluid is MIL-H-5606 and normal operating pressure is 450 to 500 psi. The pump is mounted on and driven by the main gearbox. A servo is connected to each of the three push-pull tubes that support the main rotor swashplate. The reservoir is mounted on the steel tube frame behind the main gearbox and includes a filter, pressure relief valve, and pilot-controlled pressure shut-off valve.

A sight glass for pre-flight fluid level checks is incorporated in the reservoir and is visible by opening a right side cowl door. A vented filler cap is located on top of the reservoir.

The pressure shut-off valve is solenoid-actuated and controlled by the hydraulic switch on the pilot's cyclic. The switch should be left ON during helicopter shutdown and start up except during the hydraulic system check.

### ***NOTE***

Electrical power is required to switch hydraulics OFF. Pulling HYD circuit breaker will NOT turn off hydraulics but will disable hydraulic switch.

## **CONTROL FRICTION ADJUSTMENT**

Cyclic and collective controls are equipped with adjustable friction devices. The collective friction lever is located near the aft end of the pilot's collective. It is actuated aft to increase friction and forward to release it.

The cyclic friction knob is located left of the cyclic center post. Turning the knob clockwise applies friction to both longitudinal and lateral cyclic.

### ***CAUTION***

Control friction must be used with caution during flight. Excessive friction may make the helicopter difficult to control.

The pedals actuate push-pull controls connected directly to the tail rotor pitch control and do not incorporate any friction devices.

## **ENGINE CONTROLS**

A twist-grip throttle control is located on each collective stick. The controls are interconnected and actuate the throttle valve through a mechanical linkage. The engine throttle is also correlated to collective inputs through a mechanical linkage. When the collective is raised, the throttle is opened and when the collective is lowered, the throttle is closed.

The electronic engine governor makes minor throttle adjustments by rotating the twist grip to maintain RPM within power-on limits. Manual manipulation of the twist grip is not typically required except during start up, shut down, autorotation practice, and emergencies.

An overtravel spring located in the throttle linkage allows the pilot to roll throttle off beyond the idle stop prior to a ground contact (run-on) autorotation landing. This prevents the throttle from opening when the collective is raised.

### **ENGINE CONTROLS (cont'd)**

Correct throttle linkage adjustment may be verified during preflight by rolling the twist-grip through the overtravel spring and holding against the hard idle stop. The carburetor throttle arm should just start to move when the collective is raised full up.

Other engine controls include a mixture control located forward and to the right of the cyclic center post and a carburetor heat control located to the left of the cyclic. Use of carburetor heat is described in Section 4.

### **CLUTCH ACTUATOR**

After the engine is started, it is coupled to the rotor drive system through vee-belts which are tensioned by raising the upper drive sheave. An electric actuator, located between the drive sheaves, raises the upper sheave when the pilot engages the clutch switch. The actuator senses compressive load (belt tension) and switches off when the vee-belts are properly tensioned. The clutch caution light illuminates whenever the actuator circuit is energized, either engaging, disengaging, or retensioning the belts. The light stays on until the belts are properly tensioned or completely disengaged.

Belt slack during engine start should be adjusted such that blades begin turning within five seconds of clutch engagement. Excessive slack may cause belts to jump out of sheave grooves during start. Periodic readjustment by a mechanic may be required as belts wear in service.

A fuse located on the test switch panel prevents an actuator motor overload from tripping the clutch circuit breaker. If the fuse blows, the actuator motor will stop but the clutch caution light will remain illuminated. An open circuit breaker removes power from both the motor and the light. With an open circuit breaker, no belt tensioning will occur, and the light will not function to indicate an abnormal condition.

### ***CAUTION***

Never take off while clutch caution light is on.

## **FUEL SYSTEM**

The fuel system is gravity-flow (no fuel pumps) and includes main and auxiliary tanks, a shutoff valve control located between the seats, and a strainer (gascolator). The fuel tanks have flexible bladders in aluminum enclosures. Fuel tank air vents are located inside the mast fairing.

Plunger-style drain valves are provided for the gascolator and for each fuel tank sump. The gascolator is located on the lower right side of the firewall and is drained by pushing up on the plastic tube which extends below the belly. Valves for both tanks are located inside the right cowl door below the auxiliary tank. Fuel samples are taken by extending the plastic tubes clear of the aircraft and pushing on the plungers. A glass tube stowed inside the upper, aft cowl door is provided with the helicopter and may be used to catch the fuel samples. Fuel should be sampled from all three locations prior to the first flight of the day and after refueling to verify no contamination and correct grade.

The fuel gages are electrically operated by float-type transmitters in the tanks. When the gages read E the tanks are empty except for a small quantity of unusable fuel. The low fuel caution light is actuated by a separate electric sender located on the bottom of the main tank.

The auxiliary tank is interconnected with the main tank and is located somewhat higher so it will become empty first while fuel still remains in the main tank. The fuel shutoff valve controls flow from both tanks to the engine.

## **ELECTRICAL SYSTEM**

A 28-volt DC electrical system which includes an alternator and a sealed lead-acid battery is standard. The battery is located either in the engine compartment or under the left seat.

The circuit breaker panel is on the ledge just forward of the left seat. Breakers are marked to indicate function and amperage and are of the push-to-reset type.

The battery switch controls the battery relay which disconnects the battery from the electrical system. A wire protected by a fuse near the battery bypasses the battery relay to allow both tachometers and the clock to continue to receive battery power with the battery switch off.

The alternator control unit protects the electrical system from overvoltage conditions. The ammeter indicates current to the battery ("—" indicates discharge). An ALT caution light or ammeter discharge indication in flight indicates low voltage and possible alternator failure. Turn off nonessential electrical equipment and switch alternator off then back on after one second to reset alternator control unit. If ALT light stays on or ammeter still indicates discharge, land as soon as practical.

### ***CAUTION***

Continued flight without functioning alternator can result in loss of power to tachometers, producing a hazardous flight condition.

### ***NOTE***

Except for emergency procedures, do not operate alternator with battery switched off. The battery helps protect electrical equipment from voltage spikes.

An avionics master switch controls power to the avionics bus. This allows all avionics to be switched on and off by a single switch.

**ELECTRICAL SYSTEM (cont'd)**

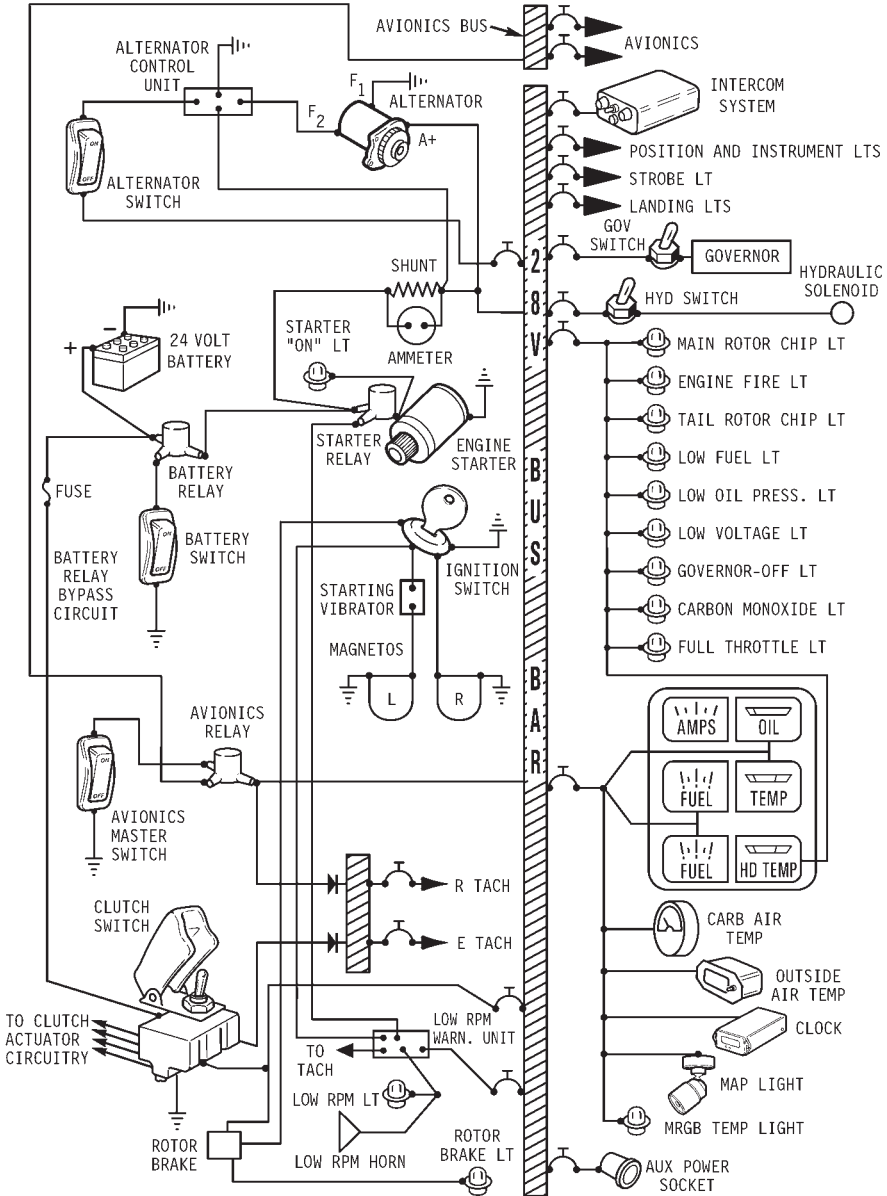

**ELECTRICAL SYSTEM**

**ELECTRICAL SYSTEM (cont'd)**

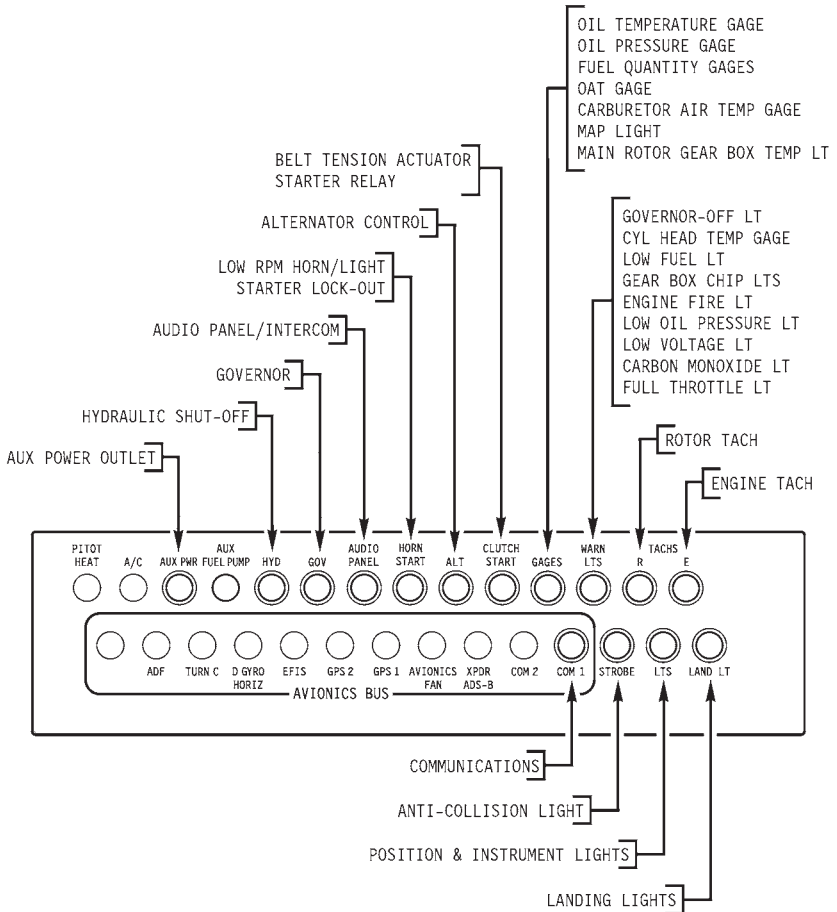

**CIRCUIT BREAKER PANEL – TYPICAL**

## **LIGHTING SYSTEM**

A red anti-collision light is installed on the tailcone and is controlled by the strobe switch. An optional flashing light may be mounted forward on the tailcone in addition to the standard anti-collision light. Position lights are installed on each side of the cabin and in the tail and are controlled by the nav lights switch. A light at the top of the windshield illuminates the instrument panel. Panel lighting is active when the nav lights switch is on and lighting is dimmed via the knob above the nav lights switch. An overhead map light mounted on a swivel is controlled by an adjacent switch with high and low settings. The map light may be used for emergency lighting of the instrument panel. An additional cabin light with an adjacent switch is located just aft of the map light.

Two landing lights are installed in the nose. One wide-angle and one narrow-beam light are used to increase the lighted area. One landing light switch controls both lights and is located on the cyclic center post.

### ***NOTE***

Landing lights operate only when clutch actuator switch is in the engage position.

### ***NOTE***

Continuous operation of landing and position lights in flight is recommended to promote collision avoidance.



### **EXTERNAL POWER RECEPTACLE (OPTIONAL)**

An optional 28-volt MS3506-compatible external power receptacle is located inside the right engine cowl door. When the battery is switched on, the external power relay and the battery relay both close, connecting external power to the aircraft electrical system and battery. The external power relay will not close if reverse polarity is sensed by the receptacle.

A separate wire from the external power receptacle to the battery bypasses the external power and battery relays. This wire allows battery charging via the external receptacle with the battery switch off. A 10-amp circuit breaker at the receptacle opens if current exceeds normal charging levels, and a diode provides polarity protection.

To use ground power for engine starting, have ground personnel connect ground power to the external receptacle prior to engaging starter, disconnect after engine start, and latch cowl door. Starts using ground power assist follow the same procedure as normal starts.

### **INSTRUMENT PANEL**

Standard primary instruments include an airspeed indicator, engine and rotor dual tachometer, altimeter, manifold pressure gage, and magnetic compass. Engine gages include an ammeter, oil pressure, oil temperature, cylinder head temperature, and fuel quantity for main and aux tanks. Also standard are a clock, a carburetor air temperature gage, and a digital outside air temperature gage. A collective-activated hourmeter is located right of the pilot's seat and may be used for recording time in service.

A view of a typical instrument panel is given on the following page. Pilots should familiarize themselves with panel layout and equipment installations for each specific aircraft that they fly.

For instrument panels with electronic flight displays, a P/N D327 light filter may be used to reduce reflections in the windshield at night. The light filter is installed by clipping it to the front of the display. Filter use is at pilot discretion.

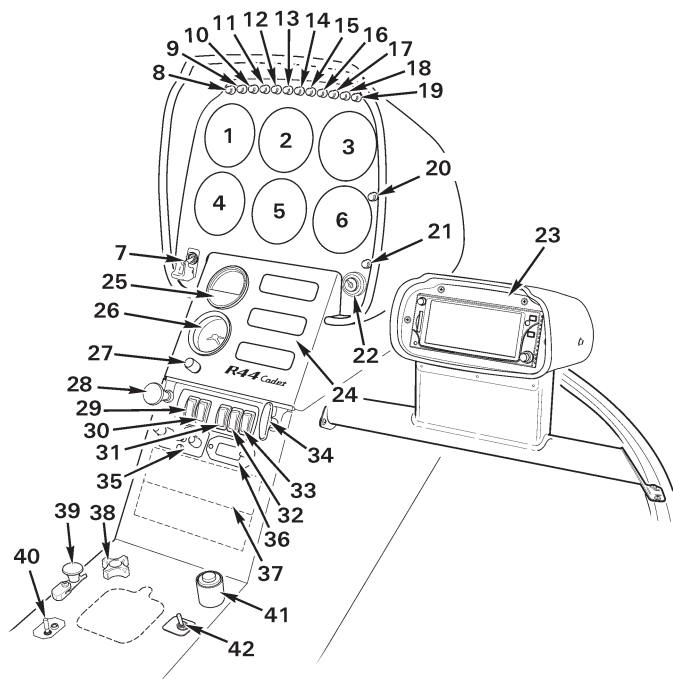

- |                             |                                  |
|-----------------------------|----------------------------------|
| 1. VERTICAL SPEED INDICATOR | 22. IGNITION SWITCH              |
| 2. AIRSPEED INDICATOR       | 23. PILOT'S SIDE CONSOLE (OPT'L) |
| 3. ENGINE AND ROTOR TACHS   | 24. ENGINE INSTRUMENTS           |
| 4. OPTIONAL INSTRUMENT      | 25. CARBURETOR AIR TEMP          |
| 5. ALTIMETER                | 26. CLOCK                        |
| 6. MANIFOLD PRESSURE GAGE   | 27. PANEL LIGHTS DIMMER          |
| 7. CLUTCH ACTUATOR SWITCH   | 28. CABIN HEAT                   |
| 8. CLUTCH ACTUATOR LIGHT    | 29. NAVIGATION LIGHTS SWITCH     |
| 9. M.R. GEARBOX TEMP LIGHT  | 30. ANTI-COLLISION LIGHT SWITCH  |
| 10. M.R. GEARBOX CHIP LIGHT | 31. AVIONICS MASTER SWITCH       |
| 11. CARBON MONOXIDE LIGHT   | 32. ALTERNATOR SWITCH            |
| 12. STARTER-ON LIGHT        | 33. BATTERY SWITCH               |
| 13. T.R. GEARBOX CHIP LIGHT | 34. CABIN AIR                    |
| 14. LOW FUEL LIGHT          | 35. INTERCOM                     |
| 15. LOW RPM LIGHT           | 36. OUTSIDE AIR TEMP/VOLTMETER   |
| 16. ALT LOW VOLTAGE LIGHT   | 37. AVIONICS STACK               |
| 17. ENGINE FIRE LIGHT       | 38. CYCLIC FRICTION              |
| 18. OIL PRESSURE LIGHT      | 39. CARBURETOR HEAT              |
| 19. GOVERNOR-OFF LIGHT      | 40. ELT SWITCH (OPTIONAL)        |
| 20. FULL THROTTLE LIGHT     | 41. MIXTURE CONTROL              |
| 21. ROTOR BRAKE LIGHT       | 42. PITOT HEAT SWITCH (OPT'L)    |

**INSTRUMENT PANEL – TYPICAL**

(Exact panel configuration may vary with optional equipment and date of helicopter manufacture.)

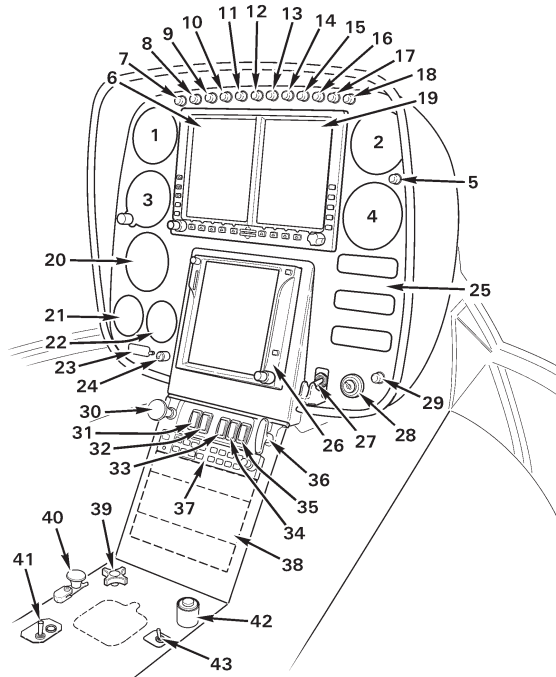

- |                             |                                 |
|-----------------------------|---------------------------------|
| 1. AIRSPEED INDICATOR       | 23. OUTSIDE AIR TEMP/VOLTMETER  |
| 2. ENGINE AND ROTOR TACHS   | 24. PANEL LIGHTS DIMMER         |
| 3. ALTIMETER                | 25. ENGINE INSTRUMENTS          |
| 4. MANIFOLD PRESSURE GAGE   | 26. GPS NAVIGATOR               |
| 5. FULL THROTTLE LIGHT      | 27. CLUTCH ACTUATOR SWITCH      |
| 6. MULTI-FUNCTION DISPLAY   | 28. IGNITION SWITCH             |
| 7. CLUTCH ACTUATOR LIGHT    | 29. ROTOR BRAKE LIGHT           |
| 8. M.R. GEARBOX TEMP LIGHT  | 30. CABIN HEAT                  |
| 9. M.R. GEARBOX CHIP LIGHT  | 31. NAVIGATION LIGHTS SWITCH    |
| 10. CARBON MONOXIDE LIGHT   | 32. ANTI-COLLISION LIGHT SWITCH |
| 11. STARTER-ON LIGHT        | 33. AVIONICS MASTER SWITCH      |
| 12. T.R. GEARBOX CHIP LIGHT | 34. ALTERNATOR SWITCH           |
| 13. LOW FUEL LIGHT          | 35. BATTERY SWITCH              |
| 14. LOW RPM LIGHT           | 36. CABIN AIR                   |
| 15. ALT LOW VOLTAGE LIGHT   | 37. AUDIO CONTROL               |
| 16. ENGINE FIRE LIGHT       | 38. AVIONICS STACK              |
| 17. OIL PRESSURE LIGHT      | 39. CYCLIC FRICTION             |
| 18. GOVERNOR-OFF LIGHT      | 40. CARBURETOR HEAT             |
| 19. PRIMARY FLIGHT DISPLAY  | 41. ELT SWITCH (OPTIONAL)       |
| 20. OPTIONAL INSTRUMENT     | 42. MIXTURE CONTROL             |
| 21. CLOCK                   | 43. PITOT HEAT SWITCH (OPT'L)   |
| 22. CARBURETOR AIR TEMP     |                                 |

**OPTIONAL INSTRUMENT PANEL**

(Exact panel configuration may vary with optional equipment and date of helicopter manufacture.)

## **AUDIO SYSTEM**

A voice-activated intercom/audio system is standard and is controlled by a small control panel above the avionics stack. The ICS volume knob controls intercom volume but does not affect radio volume. The VOX squelch knob is used to set the threshold volume at which the intercom is activated. When the VOX knob is turned fully clockwise, keying is required to activate the intercom.

A music input jack is located on a panel between the seat back rests. This input is muted when the intercom is active, when transmitting, and during reception of radio signals.

Headset jacks are located in the ceiling. Intercom and transmit are controlled by trigger switches on the cyclic grips. The trigger has two detents: the first detent activates the intercom and the second detent transmits. An additional intercom button is located on the outboard side of the left seat.

Audio control panels from several manufacturers are offered as options in place of the standard intercom system. Pilots should consult the manufacturer's operating instructions if an audio panel is installed.

## **OPTIONAL AVIONICS**

A wide range of optional avionics are available for the R44 Cadet. It is not practical to provide a description of all equipment in this manual. All aircraft are delivered with the manufacturers' operating manuals for each piece of installed equipment. Pilots are referred to the manufacturers' manuals for detailed operating instructions. Good practice dictates becoming familiar with installed equipment before operating an aircraft.

## **PITOT-STATIC SYSTEM**

The pitot-static system supplies air pressure to operate the airspeed indicator, altimeter, and vertical speed indicator. The pitot tube is located on the front edge of the mast fairing. The static sources are located on each side of the cabin aft of the rear doors.

Water can be drained from pitot-static lines by removing the plastic drain plugs which are accessible through the forward inspection panel on the underside of the cabin. Draining lines should be required only if the airspeed indicator or altimeter appears erratic.

Pitot and static sources should be inspected frequently to verify no bugs or other obstructions.

## **DUAL TACHOMETER**

An electronic engine and rotor dual tachometer is standard. Engine tachometer signal is provided by magneto breaker points. Rotor tachometer signal is provided by two magnetic senders at the main gearbox drive yoke. Each tachometer is on a separate circuit with its own circuit breaker. With battery and alternator switches off, the tachometers continue to receive power from the battery through a bypass circuit as long as the clutch actuator switch is in the engage position.

### ***NOTE***

Do not stow helicopter with clutch switch engaged. The tachometers are powered with the clutch engaged and will discharge the battery.

## **WARNING AND CAUTION LIGHTS**

Warning and caution lights include clutch, main gearbox over-temperature, main and tail gearbox chip, engine fire, starter on, low fuel, low RPM, alternator, low oil pressure, rotor brake, carbon monoxide, governor off, and full throttle. The clutch light indicates that the clutch actuator is operating. The low RPM light and horn indicate rotor RPM at 97% or below. The engine fire light is actuated by a temperature switch located at the forward end of the horizontal firewall. The low oil pressure and low fuel lights are actuated by sensors in those systems and are independent of the gage indicators. The alternator light warns of a possible alternator failure. The governor-off light indicates the RPM governor is switched off.

The main and tail gearbox chip detectors are magnetic devices located in the drain plug of each gearbox. When metallic particles are drawn to the magnets they close an electrical circuit, illuminating the caution light. Metal particles may be caused by a failing bearing or gear, thus giving warning of impending gearbox failure. The main gearbox over-temp light is actuated by a temperature switch located near the input pinion.

The carbon monoxide light is actuated by a sensor above the pilot's heater outlet and indicates elevated cabin carbon monoxide levels.

The full throttle light is activated by a switch in the throttle linkage and indicates that the engine is near full throttle.

## **CABIN HEATING AND VENTILATION**

Fresh air vents are located in each forward door and in the nose. Door vents are opened and closed using the knob near the vent door hinge. A rotating knob is provided to lock vents closed. For maximum ventilation, open door vents wide during hover but only one inch or less during cruise. The rotating knob can be used to hold vents partially open.

The fresh air inlet in the nose is opened by pulling the vent handle on console face. Rotating the vent handle clockwise will lock its position. Air from the nose inlet is directed along inside surface of the windshield for defogging as well as for ventilation.

The cabin heater consists of a muffler heat shroud, a control valve at the firewall, outlets forward of the tail rotor pedals and in the rear floor area, and interconnecting ducting. A heater control knob located on the console face actuates the valve which directs heat either into the cabin or out an overboard discharge on the cabin underside.

### ***CAUTION***

In case of an in-flight engine fire, cabin heat should be turned off to seal cabin area from engine compartment.

## **SEATS, BELTS, AND BAGGAGE**

The seats are not adjustable but the pilot-side pedals are adjustable. Each helicopter is supplied with a cushion which can be placed behind the pilot to position him farther forward. This allows shorter pilots to reach the pedals, the cyclic grip in its most forward position, and controls on the center console.

Both seats are equipped with a combined lap belt and inertia reel shoulder strap. The inertia reel is normally free but will lock if there is sudden movement as would occur in an accident.

### **SEATS, BELTS, AND BAGGAGE (cont'd)**

Five-point harnesses are optional. The lap belts on these harnesses should be adjusted to eliminate slack. On five-point harnesses, the lower strap should be adjusted as necessary to ensure that the buckle does not interfere with the cyclic grip in the full aft position. A webbing stop located above the inertia reel limits shoulder strap retraction and should be adjusted so the straps are comfortable without excessive slack.

A baggage compartment is located under each seat. Seat cushions hinge forward for access. Two additional compartments are located under the rear deck. The rear deck covers hinge forward and have lockable latches.

### **LANDING GEAR**

A skid-type landing gear is used. Most hard landings will be absorbed elastically. However, in an extremely hard landing, the struts will hinge up and outward as the crosstube yields (becomes permanently bent) to absorb the impact. Slight crosstube yielding is acceptable. However, yielding which allows the tail skid to be within 30 inches of the ground when the helicopter is sitting empty on level pavement requires crosstube replacement.

The four landing gear struts are fitted with aerodynamic fairings to reduce air drag. The helicopter is approved to fly with or without the fairings installed.

Abrasion-resistant wear shoes are mounted on the bottom of the skids. These shoes should be inspected periodically, particularly if autorotation landings with ground contact have been performed. Have skid shoes replaced whenever the thinnest point in the wear area is less than 0.06 inches (1.5 mm).



## **ROTOR BRAKE**

The rotor brake is mounted on the aft end of the main gearbox and is actuated by a cable connected to a pull handle located on the cabin ceiling. To stop the rotor, use the following procedure:

1. After pulling mixture off, wait at least 30 seconds.
2. Pull brake handle forward and down using moderate force (approximately 10 lb).
3. After rotor stops, it is recommended to use the rotor brake as a parking brake by hooking bead chain in slot in bracket.

The brake must be released before starting the engine. When the brake is engaged, the starter is disabled.

### ***CAUTION***

Applying rotor brake without waiting at least 30 seconds after engine stops or using a force which stops rotor in less than 20 seconds may damage brake shoes.

## **ENGINE PRIMER SYSTEM (OPTIONAL)**

The primer is used to improve engine cold starting. The primer pump is mounted to the steel tube frame and is accessible through the lower right cowl door. Engine priming is performed as follows:

1. Unlock pump handle and pump as required for priming (normally two to three strokes). Pull handle up slowly to allow time for fuel to fill pump.
2. After priming, push handle full down and lock.

## **CARBON MONOXIDE DETECTOR**

The carbon monoxide (CO) detector indicates elevated cabin CO levels. CO is an odorless, toxic gas present in engine exhaust which causes headaches, drowsiness, and possible loss of consciousness. CO levels may become elevated due to an exhaust leak or exhaust recirculation during prolonged hovering.

The CO detector system consists of a sensor above the pilot's heater outlet and a caution light. A system check (light flashes twice) is performed each time power is switched on. A sensor malfunction is indicated by a continuing flash every four seconds.

If the caution light illuminates, shut off heater and open nose and door vents as required to ventilate the cabin. If hovering, land or transition to forward flight. If symptoms of CO poisoning (headache, drowsiness, dizziness) accompany caution light, land immediately. Have exhaust system inspected before next flight.

Many chemicals can damage the CO sensor. Avoid use of solvents, detergents, or aerosol sprays near the sensor. Temporarily tape off openings in top and bottom of sensor housing when cleaning cabin interior.

### **EMERGENCY LOCATOR TRANSMITTER (OPTIONAL)**

The Emergency Locator Transmitter (ELT) installation consists of a transmitter with internal battery pack, an external antenna, and a remote switch/annunciator. The transmitter is mounted to the upper steel tube frame and is accessible through the aft, upper cowl door. The remote switch/annunciator is located left of the cyclic stick.

The ELT is operated by a switch on the transmitter and a remote switch in the cockpit. The transmitter switch has been secured in the AUTO or ARM position at installation and should always be in this position for flight. The remote switch/annunciator is a three position switch with indicator light. This switch should also be in the AUTO or ARMED (middle) position for flight. With both switches set to AUTO/ARM, the ELT will begin transmitting when subjected to a high "G" load. When the unit is transmitting, the red indicator light illuminates.

Moving the remote switch to ON activates the transmitter. Use the ON position if an emergency landing is imminent and time permits.

If the ELT is inadvertently activated, use the RESET position of the remote switch to stop transmission and reset the unit. The red indicator will extinguish when unit is reset.

For more detailed instructions on ELT operation, maintenance, and required tests, refer to manufacturer's instructions supplied with the unit.

**OPTIONAL ACCESSORY MOUNTS**

Provisions for mounting small, portable items are an option. The provisions use mounting bars located forward of the pilot's seat, the copilot's seat, or both. The bars are fitted with one or more clamp assemblies which are compatible with a variety of commercially available accessory mounts. There is a 10 lb total weight limit for items attached to each bar. USB and cigarette-lighter-style power outlets are installed near the inboard end of the mounting bars. The power outlets are protected by the Aux Power circuit breaker and in-line fuses and are placarded with voltage/current ratings. Wire clamps and a pocket for securing excess wire are also provided.

The accessory mounts are intended to provide a safe means of mounting small items such as portable electronic devices. The mounting bar, clamp assembly, and power outlets are approved as part of the aircraft type design, but any items attached are the responsibility of the pilot in command under appropriate operating rules. Ensure that any items attached are secure and do not interfere with flight controls or primary field of view. Route any wires through the wire clamps or secure them to the bar with cable ties or tape.

