

R66 SERVICE BULLETIN SB-18A

(supersedes R66 SB-18)

DATE: 14 June 2016

REV A: 20 July 2016

TO: R66 Owners, Operators, and Maintenance Personnel

SUBJECT: MRGB Output Yoke Retaining Plug

ROTORCRAFT AFFECTED: R66 Helicopters S/N 0004 thru 0707.

Except:

- Helicopters without air conditioning are not affected.
- Helicopter S/Ns 0373, 0430, 0543, 0575, 0581, 0595, 0596, 0607, 0656, 0670, 0676, 0702, and 0706 are not affected regardless of air conditioning equipage.

TIME OF COMPLIANCE: Within next 5 flight hours or by 31 August 2016, whichever occurs first.

BACKGROUND: RHC has received an additional report of a loose F904-1 plug, which secures the F908-1 yoke to the main gearbox. The loosened plug caused the fanwheel to move aft and contact the scroll, followed by fanwheel failure. The yoke experiences higher loads on helicopters with air conditioning due to belt tension which may cause the plug to loosen. This bulletin requires increasing the plug torque and installing additional lockwire. SB-18A has reduced the compliance time due to the additional report.

COMPLIANCE PROCEDURE:

1. Remove tailcone cowling per R66 Maintenance Manual (MM) § 53-23.
2. Refer to R66 Illustrated Parts Catalog (IPC) Figure 79-1. Remove hardware securing aft F305-5 inlet to scroll assembly; rest inlet on F196-1 fan shaft.
3. Refer to IPC Figure 65-1. Remove forward C947-3 flex plate assembly, noting hardware removed. Remove intermediate C947-3 flex plate assembly, noting hardware removed. Carefully maneuver fan shaft aft to access main gearbox's F908-1 yoke.
4. Refer to Figure 1. Set rotor brake. Remove and discard lockwire securing F904-1 plug to yoke and remove plug using a 3/4-inch hex-bit socket. Visually inspect forward C947-3 flex plate assembly and plug for damage. Order replacement parts from [RHC Customer Service](#) if damage is found.
5. Apply light coat of A257-9 anti-seize to plug threads, install plug in gearbox, and special torque plug to 60 ft-lb wet.

(OVER)

6. In two places, install 0.020-inch diameter lockwire and safety plug to yoke with pigtails inside recess of plug as shown.
7. Install forward C947-3 flex plate assembly, using hardware removed (replace palnuts). Standard torque hardware per MM § 20-32 and torque stripe per MM Figure 5-1. Ensure safety wire is not contacting flex plate.
8. Install and shim intermediate C947-3 flex plate assembly per MM § 65-30.
9. Install hardware securing aft F305-5 inlet to scroll assembly. Verify 0.10 inch minimum gap between fanwheel assembly and inlet.
10. Install tailcone cowling per MM § 53-23.
11. Make appropriate maintenance record entries. No change to helicopter weight and balance.

APPROXIMATE COST:

Parts: None required; consumables include 0.020-inch diameter lockwire, palnuts, and A257-9 anti-seize. No charge for C947-3 flex plate assembly and F904-1 plug if damaged parts are returned to RHC for exchange before 31 August 2016.

Labor: Approximately 4.0 man-hours.

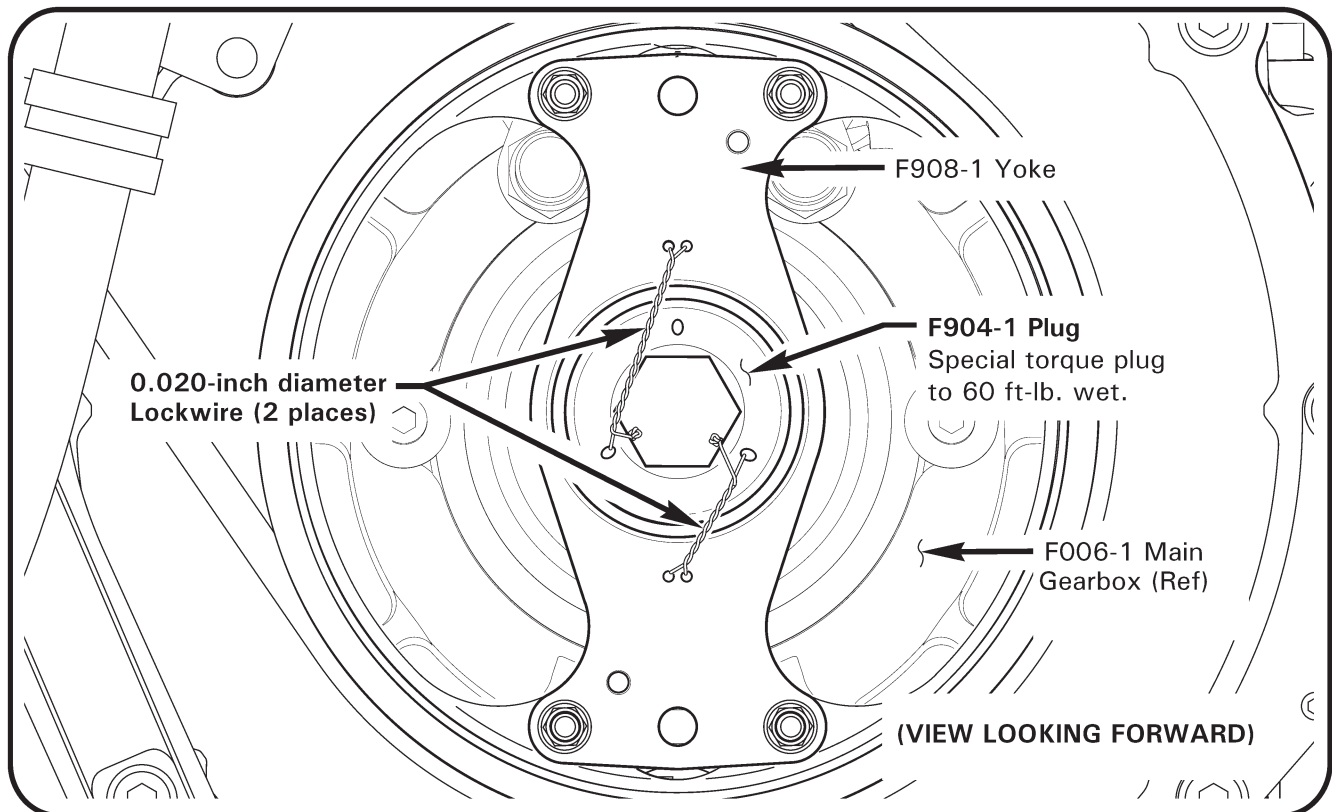

FIGURE 1

THE DESIGN ENGINEERING ASPECTS OF THIS BULLETIN HAVE BEEN SHOWN TO COMPLY WITH APPLICABLE FEDERAL AVIATION REGULATIONS AND ARE FAA APPROVED.