

CHAPTER 65

TAIL ROTOR DRIVE SYSTEM

<i>Figure</i>	<i>Title</i>	<i>Page</i>
65-1	Tail Rotor Drive Fan Shaft, Fanwheel, & Flex Plate Installation	65.0
65-3	Tail Rotor Drive Shaft Assembly & Flex Plate Installation	65.2
65-5	Hanger Bearing	65.4
65-7	Damper Assembly	65.6
65-9	Tail Rotor Gearbox Installation	65.8
65-13	Tail Rotor Gearbox Seals	65.12

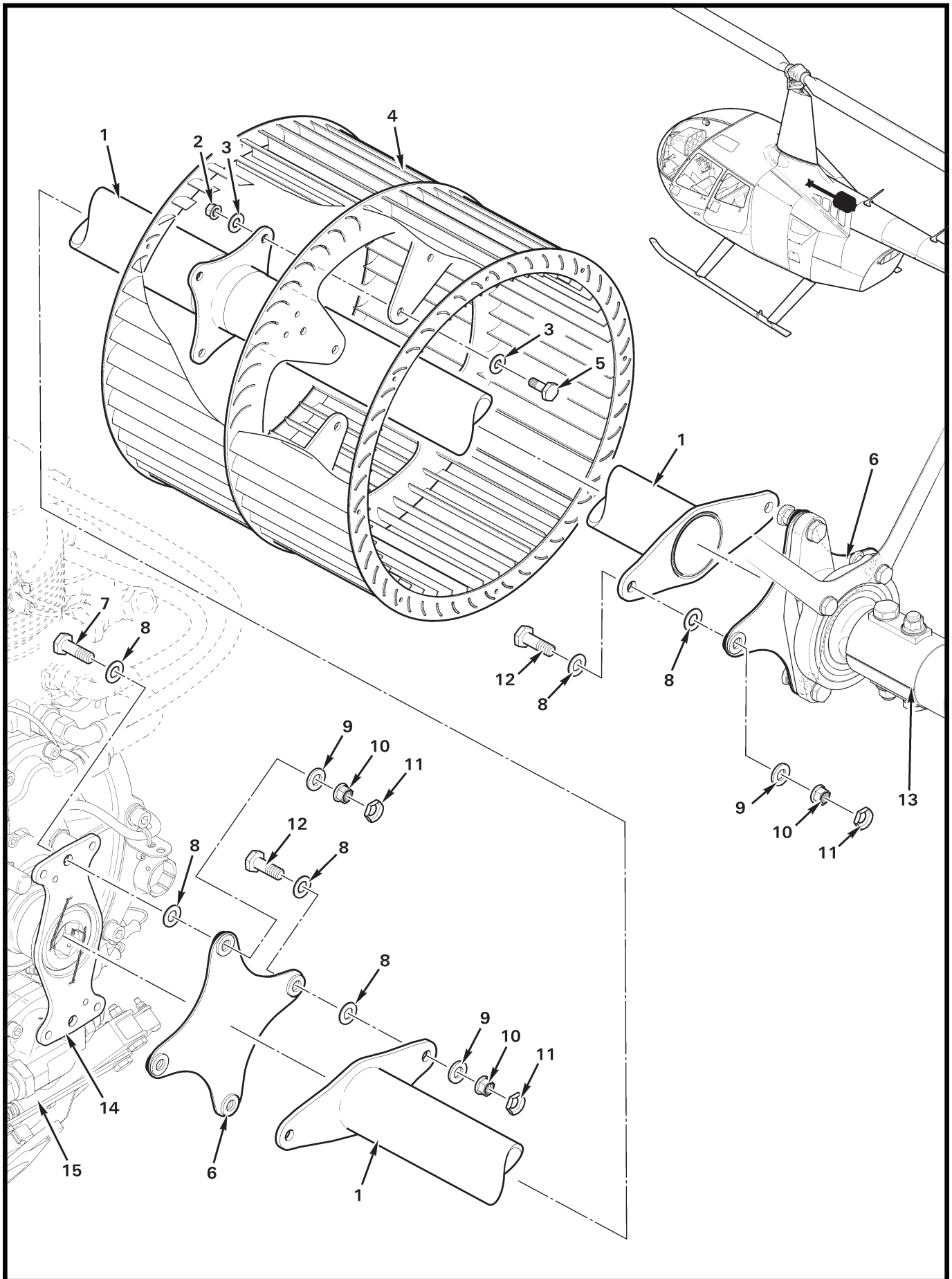

FIGURE AND INDEX NUMBER	PART NUMBER	DESCRIPTION	PARTS AVAIL	QTY PER ASSY
TAIL ROTOR DRIVE FAN SHAFT, FANWHEEL, & FLEX PLATE INSTALLATION				
65-1-1	F196-1	Tail Rotor Drive Shaft Weldment – Fan	X	1
2	D210-3	Nut	X	4
3	NAS1149F0332P	Washer	X	8
4	G174-1	Fanwheel Assembly	X	1
5	NAS6603-3	Bolt	X	4
6	C947-3	Flex Plate Assembly	X	2
7	NAS6604-6	Bolt	X	4
8	NAS1149F0432P*	Washer	X	12
9	NAS1149F0463P*	Washer	X	6
10	D210-4	Nut	X	6
11	B330-13	Palnut	X	6
12	NAS6604-5	Bolt	X	2
13	D224-4	Shaft Assembly (Ref, see Figure 65-3)		
14	F908-1	Yoke (Ref, see Figure 63-3)		
15	FO06-1	Main Rotor Gearbox Assembly (Ref; see Figure 63-3)		

NOTES * See R66 MM Chapter 65 for shimming procedure.

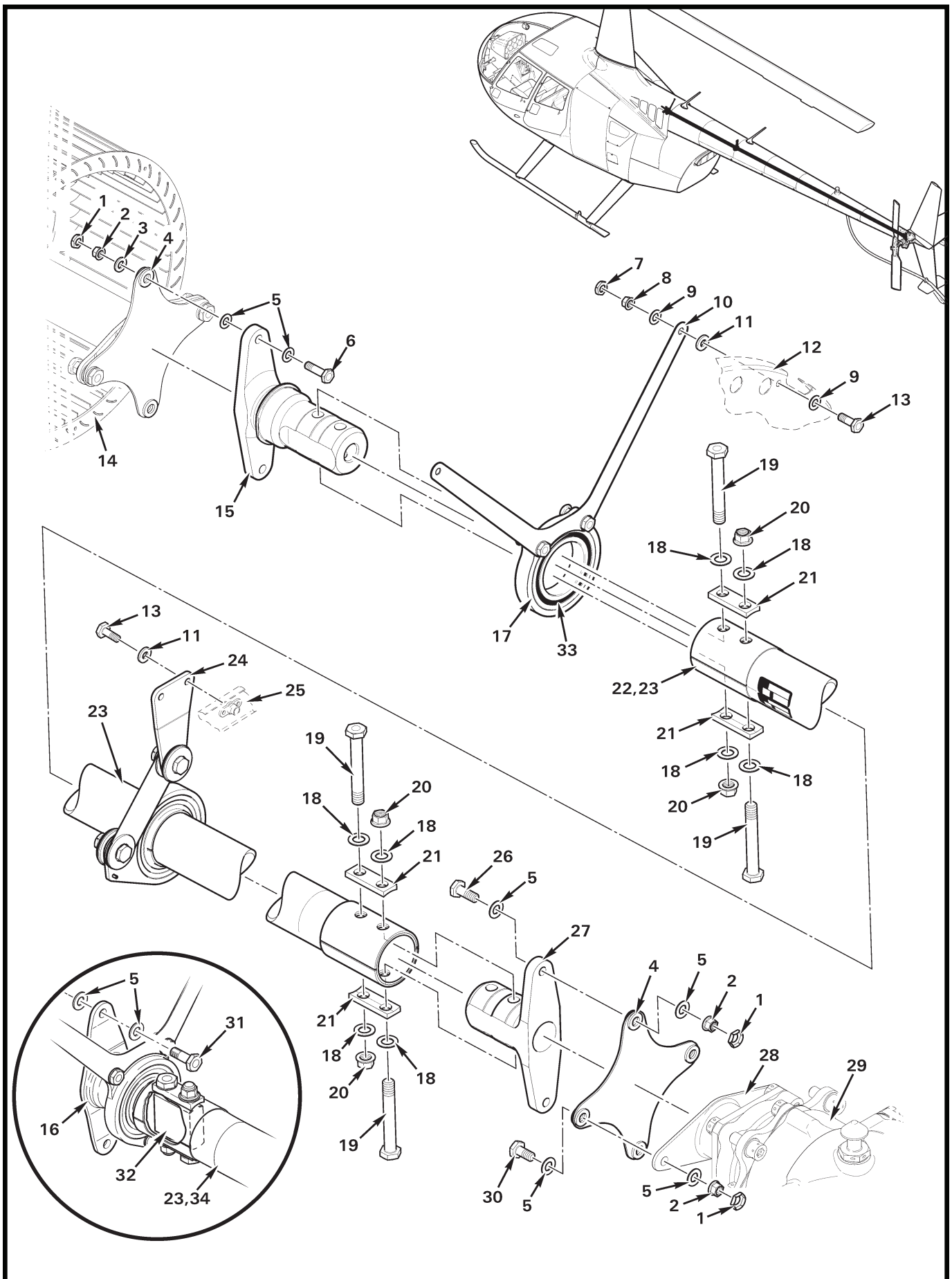

FIGURE AND INDEX NUMBER	PART NUMBER	DESCRIPTION	PARTS AVAIL	QTY PER ASSY
TAIL ROTOR DRIVE SHAFT ASSEMBLY & FLEX PLATE INSTALLATION				
65-3-1	B330-13	Palnut	X	6
2	D210-4	Nut	X	6
3	NAS1149F0463P	Washer	X	2
4	C947-3	Flex Plate Assembly	X	2
5	NAS1149F0432P	Washer	X	12
6	NAS6604-8	Bolt	X	2
7	B330-7	Palnut	X	2
8	D210-3	Nut	X	2
9	NAS1149F0332P	Washer	X	4
10	F193-2	Hanger	X	1
11	NAS1149F0363P	Washer	X	4
12	D070-1	Bulkhead Assembly – Tailcone (Ref)		
13	NAS6603-3	Bolt	X	4
14	G174-1	Fanwheel Assembly (Ref, see Figure 65-1)		
15	D195-3	Yoke	X	1
16	F195-1*	Yoke	X	1
17	F172-3	Housing – Bearing (Ref; see Figure 65-7)		
18	NAS1149F0532P	Washer	X	8
19	NAS6605-28	Bolt	X	4
20	D210-5	Nut	X	4
21	C191-7	Block	X	4
22	D224-4	Shaft Assembly (Incl items 15, 17 thru 21, 23, 24, 27, 33) . .	X	1
23	D196-1	Shaft Assembly	X	1
24	C041-12	Damper Assembly (Ref; see Figure 65-7)		
25	D072-1	Bulkhead Assembly – Tailcone (Ref)		
26	NAS6604-7	Bolt	X	2
27	D195-2	Yoke	X	1
28	C116-1	Yoke (Ref, see Figure 65-13)		
29	C021-1	Tail Rotor Gearbox Assembly (Ref, see Figure 65-9)		
30	NAS6604-4	Bolt	X	2
31	NAS6604-5	Bolt	X	2
32	A553-3*	Block	X	1
33	C647-8	Bearing (Ref; see Figure 65-5)		
34	D224-3*	Shaft Assembly (Ref; includes items 16, 23, 31, F193-1* hanger, and F172-1* bearing assembly)		

NOTES * Earlier R66s, no longer available.

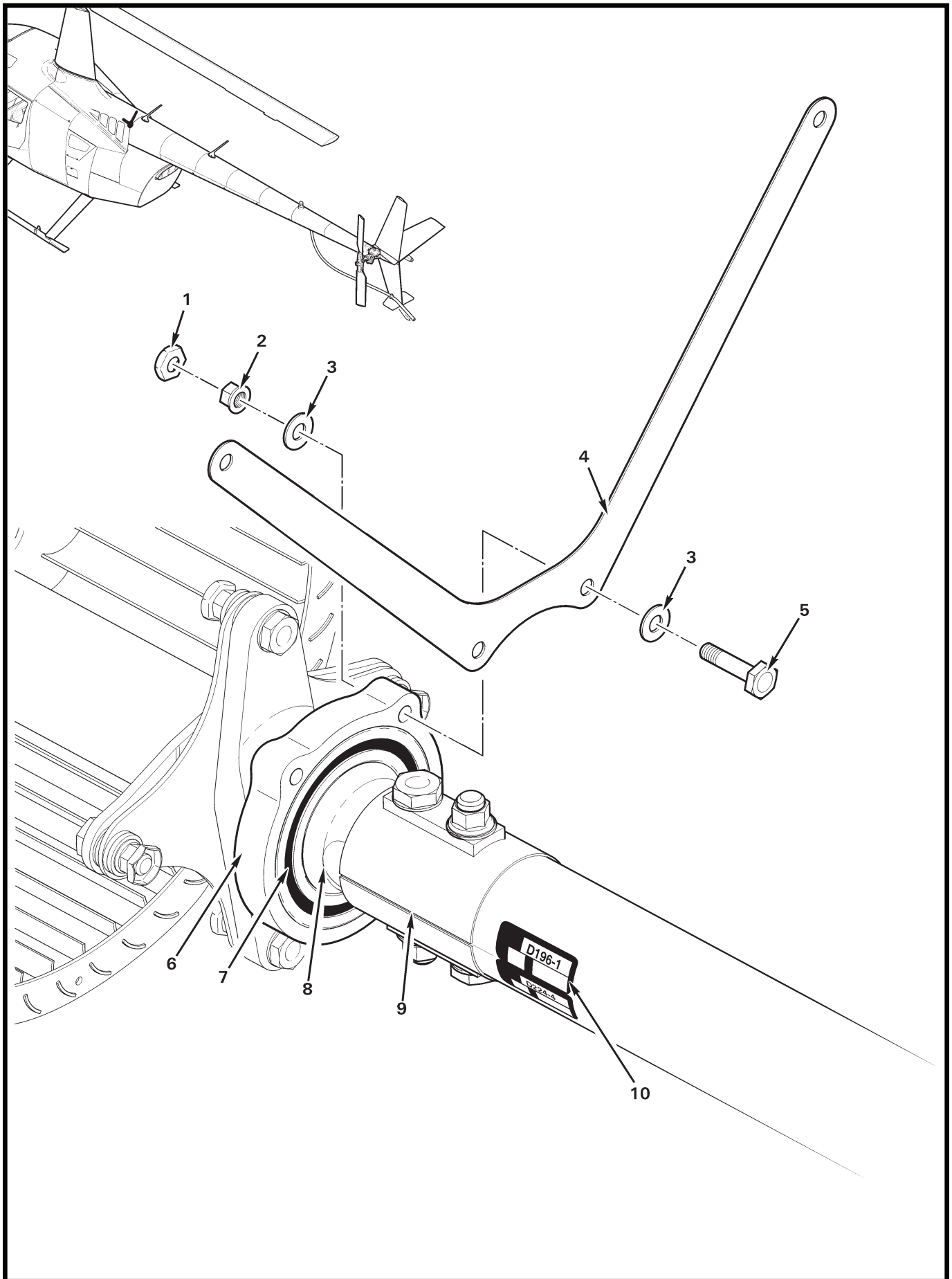

FIGURE AND INDEX NUMBER	PART NUMBER	DESCRIPTION	PARTS AVAIL	QTY PER ASSY
HANGER BEARING				
65-5-1	B330-7	Palnut	X	2
2	D210-3	Nut	X	2
3	NAS1149F0332P	Washer	X	4
4	F193-2	Hanger	X	1
5	NAS6603-8	Bolt	X	2
6	F172-3*	Housing – Bearing	X	1
7	C647-8*	Bearing	X	1
8	D195-3	Yoke (Ref)		
9	D224-4	Tail Rotor Drive Shaft Assembly (Ref; see Figure 65-3)		
10	—	Data Plate (D196-1 tail rotor drive shaft, D224-4 tail rotor drive shaft assembly; P/N, revision number, serial number) . .	O	2

NOTES * See latest version of R66 SB-20

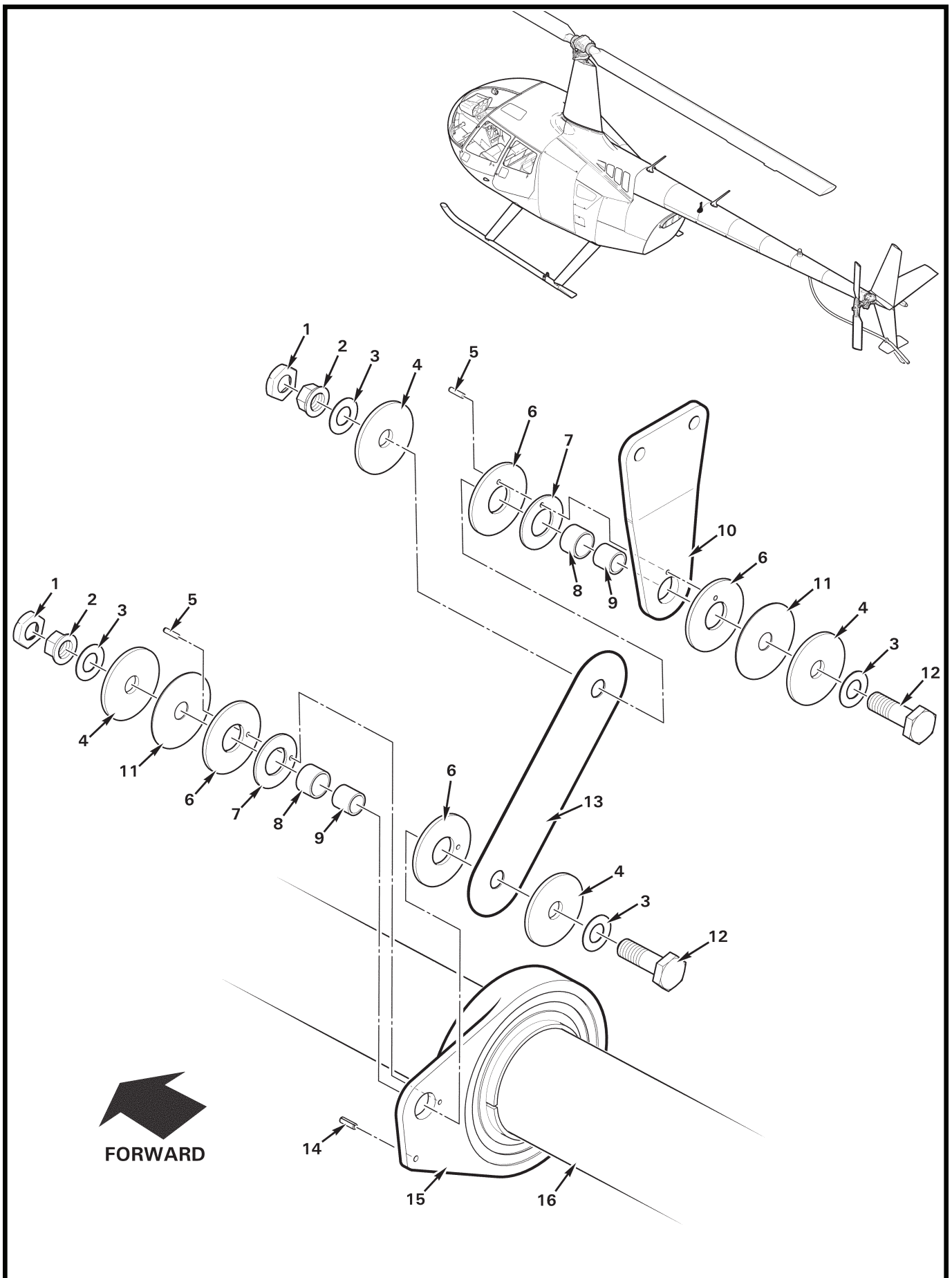

FIGURE AND INDEX NUMBER	PART NUMBER	DESCRIPTION	PARTS AVAIL	QTY PER ASSY
DAMPER ASSEMBLY				
65-7-1	B330-13	Palnut	X	2
2	D210-4	Nut	X	2
3	NAS1149D0416J	Washer	X	4
4	A141-37	Washer	X	4
5	A041-10	Dowel Pin	X	2
6	C041-5	Washer	X	4
7	C041-6	Spring Washer	X	2
8	05DU04	Bushing	X	2
9	A105-12	Journal	X	2
10	C041-13	Arm	X	1
11	A141-36	Washer	X	2
12	NAS6604-6	Bolt	X	2
13	C041-3	Link	X	1
14	MS16562-11	Pin	X	1
15	C041-11*	Bearing Assembly	X	1
16	D224-3	Tail Rotor Drive Shaft Assembly (Ref)		

NOTES * See latest version of R66 SB-20

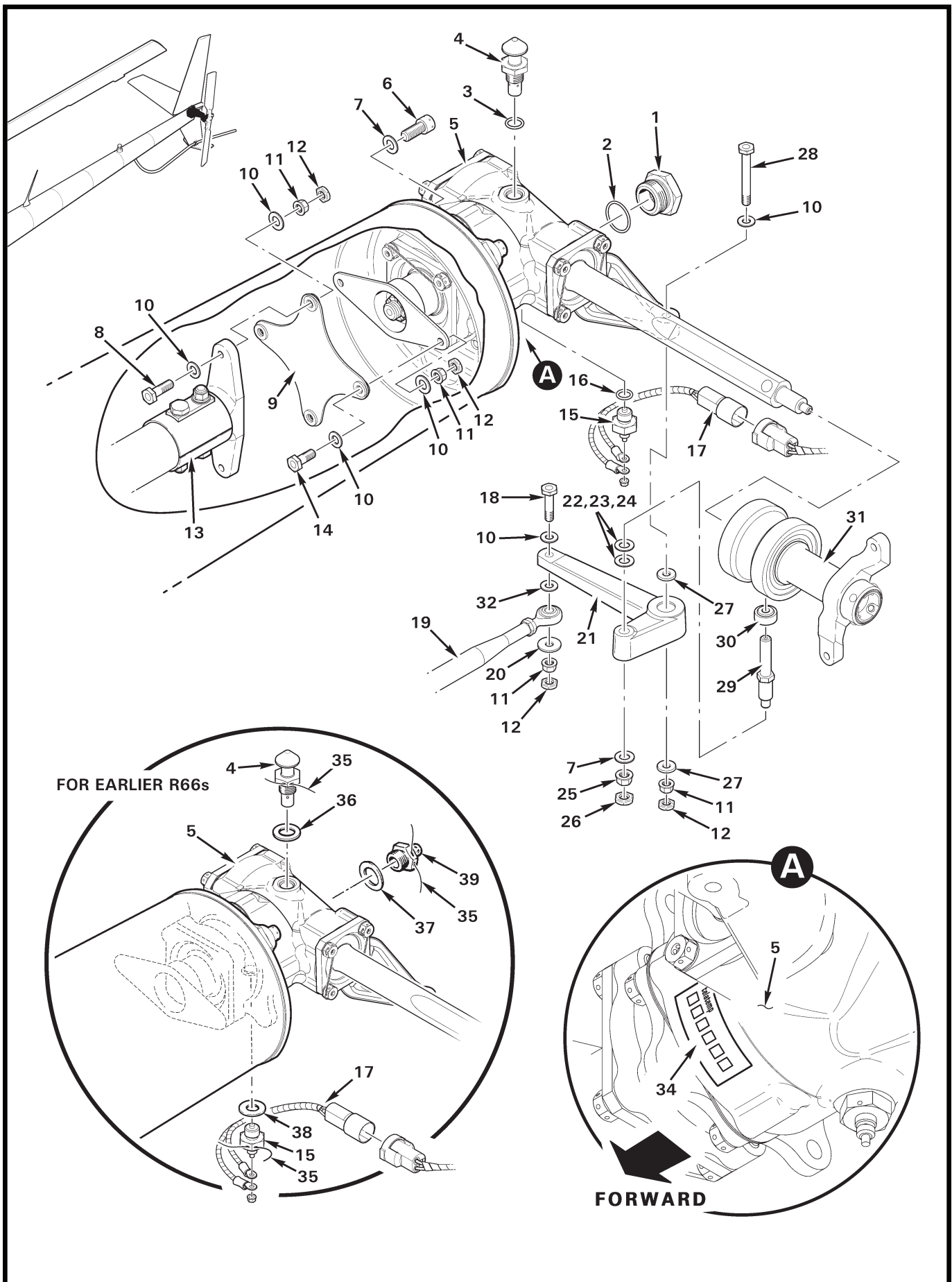

FIGURE AND INDEX NUMBER	PART NUMBER	DESCRIPTION	PARTS AVAIL	QTY PER ASSY
TAIL ROTOR GEARBOX INSTALLATION				
65-9-1	B563-4	Sight Gage (with UV filter)	X	1
	B563-2	Sight Gage (Ref, earlier helicopters)		
2	A215-020	O-Ring	X	1
3	MS28778-5	Packing (o-ring)	X	1
4	A610-1	Filler-Vent Plug	X	1
5	C021-1	Tail Rotor Gearbox Assembly (Includes items 1 thru 4, 15 thru 17, 33, and 34. See also Figure 65-13.)	X	1
	C021-1R	C021-1 Gearbox Assembly – Tail Rotor (overhaul exchange) . .	X	1
6	NAS1352-5-12P	Screw	X	4
7	NAS1149F0532P	Washer	X	5
8	NAS6604-7	Bolt	X	2
9	C947-3	Flex Plate Assembly (Ref, see Figure 65-3)		
10	NAS1149F0432P	Washer	X	6
11	D210-4	Nut	X	6
12	B330-13	Palnut	X	6
13	D224-3	Tail Rotor Drive Shaft Assembly (Ref, see Figure 65-3)		
14	NAS6604-4	Bolt	X	2
15	B566-2	Chip Detector (includes nut)	X	1
16	MS28778-4	Packing (o-ring)	X	1
17	C049-1	Harness Assembly (chip detector)	X	1
18	NAS6604-10	Bolt (or NAS6604-11)	X	1
19	C121-17	Push-Pull Tube Assembly (Ref, see Figure 67-39)		
20	A214-3	Washer	X	1
21	A120-5	Bellcrank Assembly	X	1
22	C117-34	Shim – Washer (thickness = 0.016 inch)	X	A/R
23	C117-35	Shim – Washer (thickness = 0.020 inch)	X	A/R
24	C117-36	Shim – Washer (thickness = 0.026 inch)	X	A/R
25	D210-5	Nut	X	1
26	B330-16	Palnut	X	1
27	MS20002-4	Washer	X	2
28	NAS6604-25	Bolt	X	1
29	C125-1	Stud	X	1
30	A104-4	Bearing	X	1
31	C031-1	Pitch Control Assembly (Incl items 28 and 29)	X	1
32	NAS1149F0432P	Washer (or NAS1149F0463P to maintain clearance)	X	A/R

NOTES

Continues

FIGURE AND INDEX NUMBER	PART NUMBER	DESCRIPTION	PARTS AVAIL	QTY PER ASSY
TAIL ROTOR GEARBOX INSTALLATION (Cont'd)				
65-9-33	C545-1	Gear Set (Ref, not shown)		
34	F110-2	Teletemp (Temperature Recorder, 140°–190° F) * * *	X	1
35	MS20995C32*	0.032 in. dia. Safety Wire	X	A/R
36	MS35769-9*	Gasket	X	1
37	MS35769-11*	Gasket	X	1
38	MS35769-8*	Gasket	X	1
39	B563-1*	Sight Gage	X	1

NOTES * Earlier R66s.

Intentionally Blank

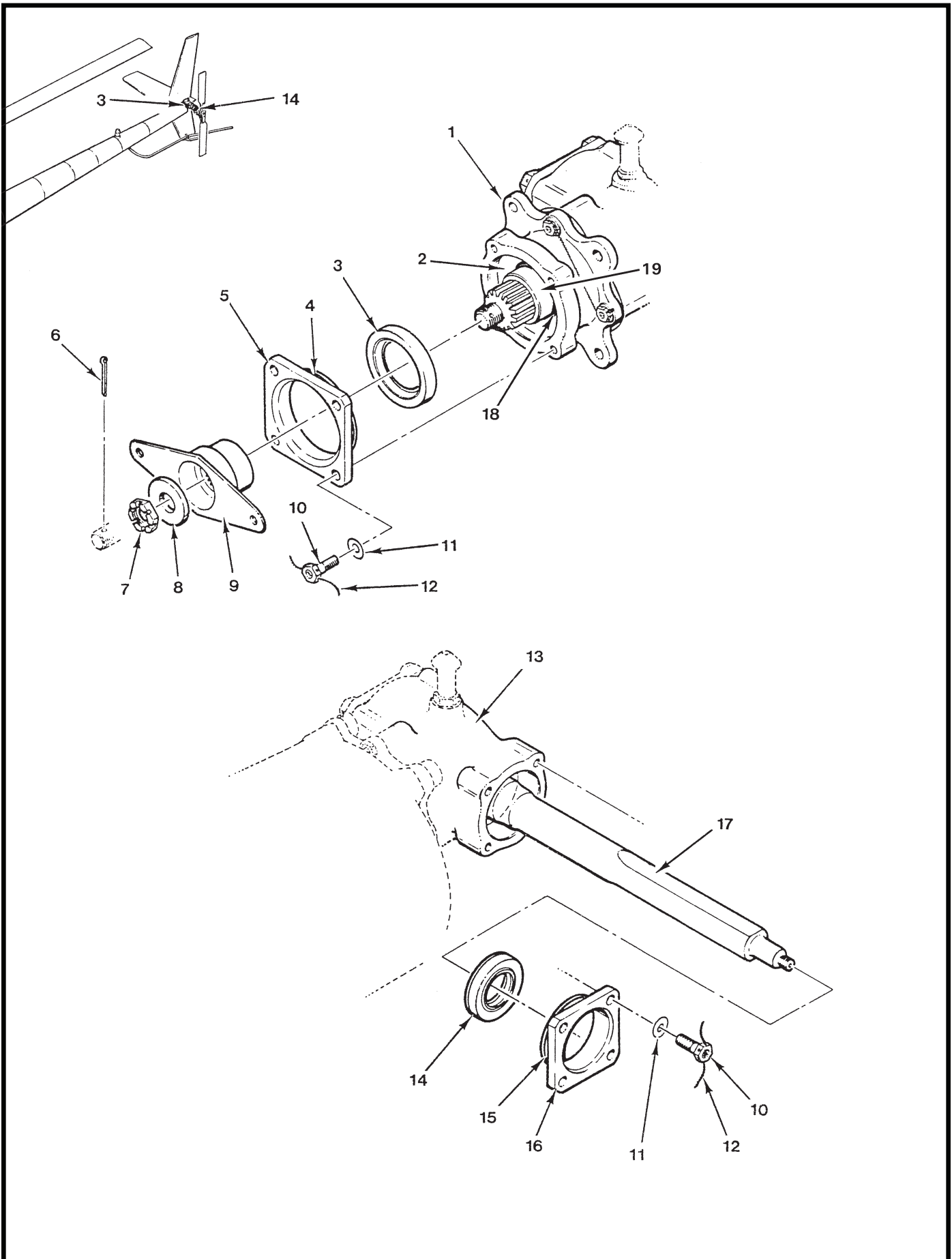

FIGURE AND INDEX NUMBER	PART NUMBER	DESCRIPTION	PARTS AVAIL	QTY PER ASSY
TAIL ROTOR GEARBOX SEALS				
65-13-1	C110-1	Input Cartridge (Ref)		
2	C141-2	Washer (Ref, between cap and input cartridge)		
3	A966-3	Seal	X	1
4	A215-140	O-Ring	X	1
5	C112-1	Cap	X	1
6	MS24665-210	Cotter Pin	X	1
7	AN320-8	Nut	X	1
8	A141-10	Washer	X	1
9	C116-1	Yoke	X	1
10	MS20074-04-06	Bolt	X	8
11	NAS1149F0432P	Washer	X	8
12	MS20995C32	0.032 in. dia Safety Wire	X	A/R
13	C109-1	Housing (Ref)		
14	C966-2	Seal	X	1
15	A215-133	O-Ring	X	1
16	C112-2	Cap	X	1
17	C107-1	Shaft – Output (Ref)		
18	A215-024	O-Ring	X	1
19	C266-2	Spacer	X	1

NOTES

Intentionally Blank