

SERVICE LETTER #3

DATE: 28 July 1994

TO: All R44 Owners and Operators

SUBJECT: Cyclic "Shot Bag" Damper

ROTORCRAFT AFFECTED: R44 Helicopter S/N's 0001 thru 0087

BACKGROUND: RHC has received two reports of the cyclic damper leaking lead shot. The cyclic damper has been redesigned to make it more durable.

COMPLIANCE PROCEDURE:

- 1) Order from RHC one C683-2 bag assembly and two MS3367-3-9 ty-raps.
- 2) Remove C683-3 vinyl cover by untying cord and separating velcro.
- 3) After carefully noting orientation and location of ty-raps on present installation, cut and remove them (the new bag assembly will be attached the same way). Remove C683-2 bag assembly from cyclic stick.
- 4) Install new C683-2 bag assembly using the two MS3367-3-9 ty-raps. Locate and install ty-raps as shown in Figure 1. Make sure bag is firmly attached to cyclic stick, and that cyclic T-bar pivots freely.
- 5) Reinstall vinyl cover.

Approximate Cost:

PARTS: No Cost

LABOR: 0.2 manhours

INSERT TY-RAP BETWEEN
STITCHES ON BOTH SIDES
OF BAG.

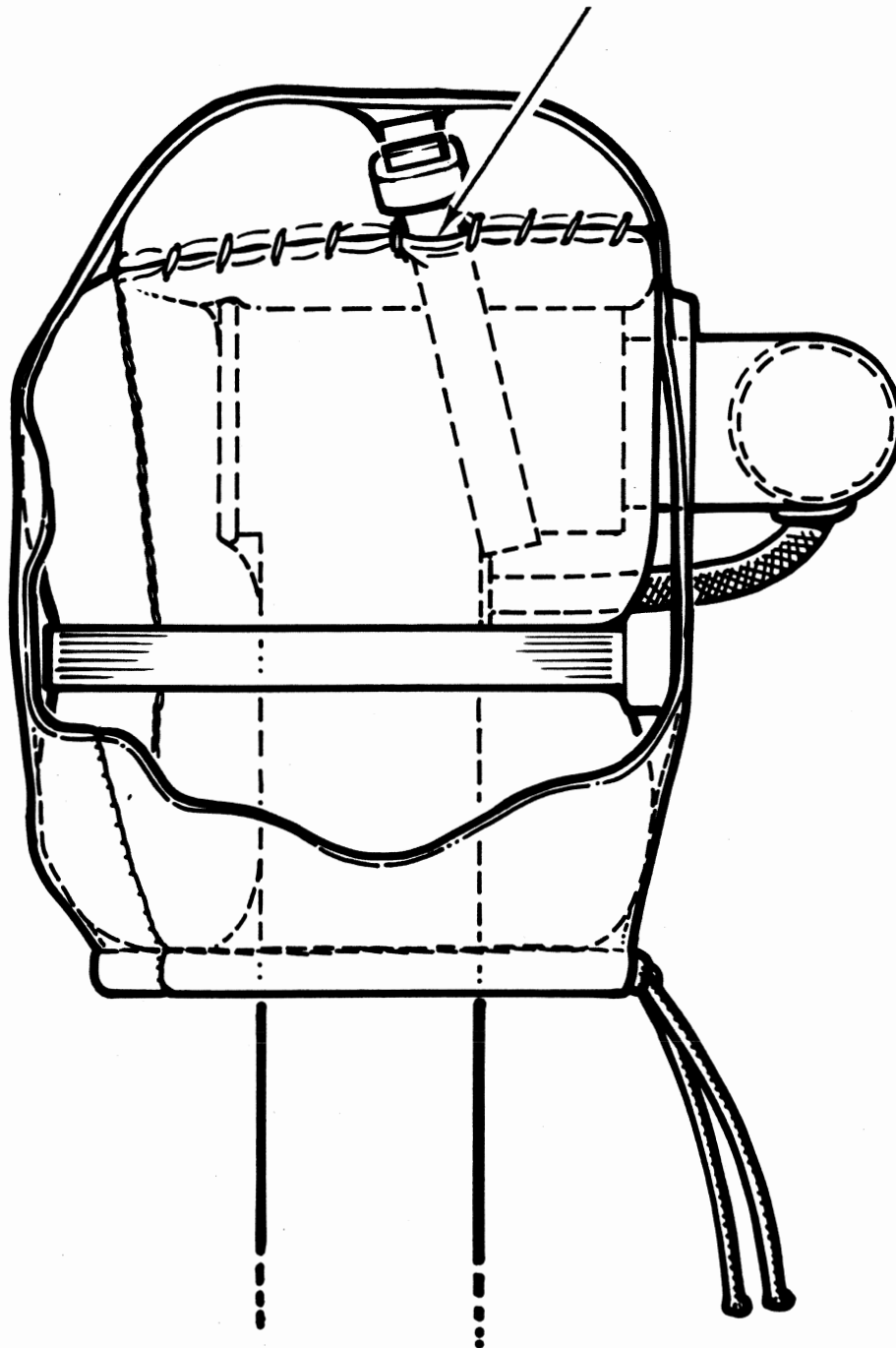

FIGURE 1